

## Product Overview

The NCA9546 is a quad bidirectional translating switch controlled via the I<sup>2</sup>C bus. The SCL/SDA upstream pair fans out to four downstream pairs, or channels. Any individual SCn/SDn channel or combination of channels can be selected, determined by the contents of the programmable control register.

An active-low reset ( $\overline{\text{RESET}}$ ) input allows the NCA9546 to recover from a situation in which one of the downstream I<sup>2</sup>C buses is stuck in a low state. Pulling  $\overline{\text{RESET}}$  low resets, the I<sup>2</sup>C state machine and causes all the channels to be deselected, as does the internal power-on reset function.

The pass gates of the switches are constructed such that the VCC terminal can be used to limit the maximum high voltage, which will be passed by the NCA9546. This allows the use of different bus voltages on each pair, so that 1.8-V, 2.5-V, or 3.3-V parts can communicate with 5-V parts, without any additional protection. External pull-up resistors pull the bus up to the desired voltage level for each channel. All I/O terminals are 5.5 V tolerant.

## Key Features

- 1-of-4 Bidirectional Translating Switches
- I<sup>2</sup>C Bus and SMBus Compatible
- Active-Low Reset Input
- Three Address Terminals, Allowing up to Four Devices on the I<sup>2</sup>C Bus
- Channel Selection via I<sup>2</sup>C Bus, in Any Combination
- Power-Up with All Switch Channels Deselected
- Low R<sub>ON</sub> Switches
- Allows Voltage-Level Translation Between 1.8-V, 2.5-V, 3.3-V, and 5-V Buses
- No Glitch on Power-Up
- Supports Hot Insertion

- Low Standby Current
- Operating Power-Supply Voltage Range of 1.7 V to 5.5 V
- 5.5 V Tolerant Inputs
- 0 to 400-kHz Clock Frequency
- Latch-Up Performance Exceeds 100 mA per JESD 78
- ESD Protection Exceeds JESD 22
  - 2000-V Human-Body Model (A114-A)
  - 1000-V Charged-Device Model (C101)

## Applications

- Servers
- Routers (Telecom Switching Equipment)
- Factory Automation
- Products with I<sup>2</sup>C Slave Address Conflicts (e.g. Multiple, Identical Temp Sensors)

## Device Information

Part Number	Package	Body Size
NCA9546-DTSPR	TSSOP16	5.0mm*4.4mm

## Functional Block Diagrams

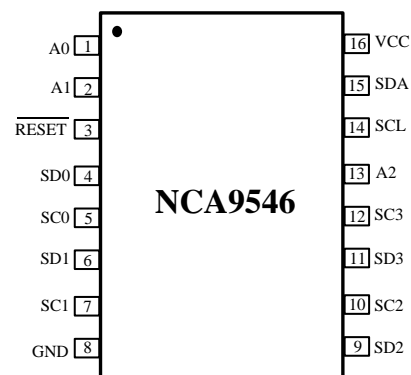

Figure 1. NCA9546 Block Diagram

## INDEX

1. PIN CONFIGURATION AND FUNCTIONS .....	3
2. ABSOLUTE MAXIMUM RATINGS .....	4
3. RECOMMENDED OPERATING CONDITIONS .....	4
4. THERMAL INFORMATION .....	4
5. SPECIFICATIONS.....	5
5.1. ELECTRICAL CHARACTERISTICS .....	5
5.2. DYNAMIC CHARACTERISTICS .....	6
5.3. PARAMETER MEASUREMENT INFORMATION .....	6
6. DETAILED DESCRIPTION .....	8
6.1. OVERVIEW .....	8
6.2. FUNCTIONAL BLOCK DIAGRAM .....	9
6.3. FEATURE DESCRIPTION.....	9
6.4. DEVICE FUNCTIONAL MODES .....	9
6.5. RESET INPUT .....	9
6.6. POWER-ON RESET.....	10
6.7. PROGRAMMING .....	10
6.8. I <sup>2</sup> C INTERFACE .....	10
6.9. CONTROL REGISTER .....	11
6.10. DEVICE ADDRESS .....	11
6.11. CONTROL REGISTER DESCRIPTION.....	11
6.12. CONTROL REGISTER DEFINITION .....	12
7. APPLICATION AND IMPLEMENTATION .....	13
7.1. TYPICAL APPLICATION.....	13
7.2. DESIGN REQUIREMENTS.....	14
7.3. DETAILED DESIGN PROCEDURE .....	14
7.4. NCA9546 APPLICATION CURVES.....	14
8. LAYOUT .....	15
8.1. LAYOUT GUIDELINES.....	15
9. PACKAGE INFORMATION .....	17
10. ORDER INFORMATION.....	17
11. DOCUMENTATION SUPPORT .....	17
12. TAPE AND REEL INFORMATION.....	18
13. REVISION HISTORY .....	19

## 1. Pin Configuration and Functions

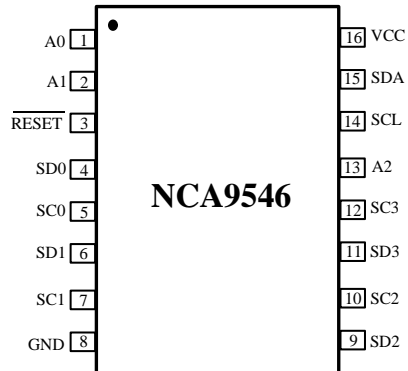

Figure 1.1 NCA9546 Package

Table 1.1 Pin Configuration and Description

Symbol	Pin	Description
A0	1	Address input 0. Connect directly to VCC or ground.
A1	2	Address input 1. Connect directly to VCC or ground.
$\overline{\text{RESET}}$	3	Active-low reset input. Connect to VCC or $V_{\text{DPUM}}^1$ through a pull-up resistor if not used.
SD0	4	Serial data 0. Connect to $V_{\text{DPU0}}^1$ through a pull-up resistor.
SC0	5	Serial clock 0. Connect to $V_{\text{DPU0}}^1$ through a pull-up resistor.
SD1	6	Serial data 1. Connect to $V_{\text{DPU1}}^1$ through a pull-up resistor.
SC1	7	Serial clock 1. Connect to $V_{\text{DPU1}}^1$ through a pull-up resistor.
GND	8	Ground
SD2	9	Serial data 2. Connect to $V_{\text{DPU2}}^1$ through a pull-up resistor.
SC2	10	Serial clock 2. Connect to $V_{\text{DPU2}}^1$ through a pull-up resistor.
SD3	11	Serial data 3. Connect to $V_{\text{DPU3}}^1$ through a pull-up resistor.
SC3	12	Serial clock 3. Connect to $V_{\text{DPU3}}^1$ through a pull-up resistor.
A2	13	Address input 2. Connect directly to VCC or ground.
SCL	14	Serial clock line. Connect to $V_{\text{DPUM}}^1$ through a pull-up resistor.
SDA	15	Serial data line. Connect to $V_{\text{DPUM}}^1$ through a pull-up resistor.
VCC	16	Supply power

<sup>1</sup>  $V_{\text{DPUX}}$  is the pull-up reference voltage for the associated data line.  $V_{\text{DPUM}}$  is the master I<sup>2</sup>C master reference voltage and  $V_{\text{DPU0}}-V_{\text{DPU3}}$  are the slave channel reference voltages.

## 2. Absolute Maximum Ratings

Parameters	Symbol	Min	Max	Unit	Conditions
Supply Voltage	$V_{CC}$	-0.5	7	V	
Input/output Voltage	$V_I/V_O$	-0.5	7	V	
Input current	$I_I$		$\pm 25$	mA	
Output current	$I_O$		$\pm 25$	mA	$V_O < 0V$
Continuous current through VCC or GND	$I_{CC}$		$\pm 100$	mA	
Operating Temperature	$T_{opr}$	-40	105	$^{\circ}C$	
Storage Temperature	$T_{stg}$	-40	150	$^{\circ}C$	
Electrostatic discharge	HBM		$\pm 2000$	V	
	CDM		$\pm 1000$	V	

## 3. Recommended Operating Conditions

Parameters	Symbol	Min	Max	Unit	Conditions
Supply voltage	$V_{CC}$	1.7	5.5	V	
High-level input voltage	$V_{IH}$	$0.7 \cdot V_{CC}$	6	V	SCL, SDA
		$0.7 \cdot V_{CC}$	$V_{CC} + 0.5$	V	A1, A0, INT3–INT0, RESET
Low-level input voltage	$V_{IL}$	-0.5	$0.3 \cdot V_{CC}$	V	SCL, SDA
		-0.5	$0.3 \cdot V_{CC}$	V	A1, A0, INT3–INT0, RESET
Operating free-air temperature	$T_A$	-40	105	$^{\circ}C$	

## 4. Thermal Information

Parameters	Symbol	Unit
Junction-to-ambient thermal resistance	$\theta_{JA}$	$115.3$ $^{\circ}C/W$
Junction-to-case(top) thermal resistance	$\theta_{JC (top)}$	$48.7$ $^{\circ}C/W$
Junction-to-board thermal resistance	$\theta_{JB}$	$66.4$ $^{\circ}C/W$

## 5. Specifications

### 5.1. Electrical Characteristics

$V_{CC} = 1.7V$  to  $5.5V$ ;  $T_{amb} = -40^{\circ}C$  to  $+105^{\circ}C$ ; unless otherwise noted. Typical specification are at  $T_A=25^{\circ}C, V_{CC}=3.3V$

Parameters	Symbol	Min	Typ	Max	Unit	Conditions
<b>Supply</b>						
Supply voltage Range	$V_{CC}$	1.7	-	5.5	V	
Power On Reset rising	$V_{PORR}$	-	1.15	1.4	V	no load; $V_I = V_{CC}$ or GND
Power On Reset falling	$V_{PORF}$	0.9	1.08		V	no load; $V_I = V_{CC}$ or GND
Supply current	$I_{CC}$	-	-	10	$\mu A$	Operating mode; $V_{CC} = 5.5 V$ ; $V_I = V_{CC}$ or GND; no load; $f_{SCL} = 100 kHz$
Standby current	$I_{stb}$	-	0.3	5	$\mu A$	Standby mode; $V_{CC} = 5.5 V$ ; $V_I = V_{CC}$ or GND; no load
<b>Input SCL; Input/Output SDA</b>						
LOW-level input voltage	$V_{IL}$	-0.5	-	$0.3 \cdot V_{CC}$	V	
HIGH-level input voltage	$V_{IH}$	$0.7 \cdot V_{CC}$	-	6	V	When $V_{CC}=1.7V-2.3V$ , the minimum value of $V_{IH}$ is $0.8 \cdot V_{CC}$
LOW-level output current	$I_{OL}$	2.5	15	-	mA	$V_{OL}=0.4V$
		4	20		mA	$V_{OL}=0.6V$
Input leakage current	$I_L$	-1	-	+1	$\mu A$	$V_I = V_{CC}$ or GND
Input capacitance	$C_i$	-	15		pF	$V_I = GND$
<b>Select inputs A0,A1, RESET</b>						
LOW-level input voltage	$V_{IL}$	-0.5	-	$0.3 \cdot V_{CC}$	V	
HIGH-level input voltage	$V_{IH}$	$0.7 \cdot V_{CC}$	-	6	V	When $V_{CC}=1.7V-2.3V$ , the minimum value of $V_{IH}$ is $0.8 \cdot V_{CC}$
Leakage current	$I_L$	-1	-	1	$\mu A$	$V_I = V_{CC}$ or GND
Input capacitance	$C_i$	-	1.6	3	pF	$V_I = GND$
<b>Pass gate</b>						
On-state resistance	$R_{on}$	4	14	20	$\Omega$	$V_o=0.4 V, I_o = 15 mA, V_{CC} = 4.5V$
		5	16	25		$V_o=0.4 V, I_o = 15 mA, V_{CC} = 3V$
		6	19	30		$V_o=0.4 V, I_o = 10 mA, V_{CC} = 2.3V$
		10	28	40		$V_o=0.4 V, I_o = 10 mA, V_{CC} = 1.7V$
Switch output voltage	$V_{O(SW)}$		3.64		V	$V_{CC} = 5 V, I_{O(SW)} = -100\mu A$
		2.6		4.5		$V_{CC} = 4.5V$ to $5.5 V, I_{O(SW)} = -100\mu A$
			2.15			$V_{CC} = 3.3 V, I_{O(SW)} = -100\mu A$
		1.6		2.8		$V_{CC} = 3 V$ to $3.6 V, I_{O(SW)} = -100\mu A$
			1.46			$V_{CC} = 2.5 V, I_{O(SW)} = -100\mu A$
		1		1.9		$V_{CC} = 2.3 V$ to $2.7 V, I_{O(SW)} = -100\mu A$
			0.99			$V_{CC} = 1.8 V, I_{O(SW)} = -100\mu A$

		0.5		1.2		$V_{CC} = 1.7\text{ V to }1.95\text{ V, }I_{O(SW)} = -100\mu\text{A}$
Leakage current	$I_L$	-1	-	+1	$\mu\text{A}$	$V_I = V_{CC}\text{ or GND}$
$C_{io}$	Input/output capacitance	-	-	6	pF	$V_I = \text{GND}$

## 5.2. Dynamic Characteristics

Parameters	Symbol	Standard-mode I2C-bus		Fast-mode I2C-bus		Unit
		Min	Max	Min	Max	
propagation delay	$t_{PD}^1$		0.3		0.3	ns
SCL clock frequency	$f_{SCL}$	0	100	0	400	kHz
bus free time between a STOP and START condition	$t_{BUF}$	4.7	-	1.3	-	$\mu\text{s}$
hold time (repeated) START condition	$t_{HD,STA}^2$	4.0	-	0.6	-	$\mu\text{s}$
set-up time for a repeated START condition	$t_{SU,STA}$	4.7	-	0.6	-	$\mu\text{s}$
set-up time for STOP condition	$t_{SU,STO}$	4.0	-	0.6	-	$\mu\text{s}$
data valid acknowledge time	$t_{VD,ACK}$	0.3	3.45	0.1	0.9	$\mu\text{s}$
data hold time	$t_{HD,DAT}^3$	0	-	0	-	ns
data valid time	$t_{VD,DAT}^4$	300	-	50	-	ns
data set-up time	$t_{SU,DAT}$	250	-	100	-	ns
LOW period of the SCL clock	$t_{LOW}$	4.7	-	1.3	-	$\mu\text{s}$
HIGH period of the SCL clock	$t_{HIGH}$	4.0	-	0.6	-	$\mu\text{s}$
fall time of both SDA and SCL signals	$t_f$	-	300	20 + $0.1C_b^5$	300	ns
rise time of both SDA and SCL signals	$t_r$	-	1000	20 + $0.1C_b^5$	300	ns
pulse width of spikes that must be suppressed by the input filter	$t_{SP}$	-	50	-	50	ns
data output valid time	$t_{V(Q)}$	-	200	-	200	ns
data input set-up time	$t_{su(D)}$	150	-	150	-	ns
data input hold time	$t_{h(D)}$	1	-	1	-	$\mu\text{s}$
<b>RESET</b>						
Low-level reset time	$T_{w(rst)L}$	4		4		ns
Reset time	$t_{rst}$	500		500		ns
Recovery time to START condition		0		0		ns

<sup>1</sup>Pass gate propagation delay is calculated from the 20  $\Omega$  typical Ron and the 15 pF load capacitance.

<sup>2</sup>After this period, the first clock pulse is generated.

<sup>3</sup>A device must internally provide a hold time of at least 300 ns for the SDA signal (referred to the  $V_{IH(min)}$  of the SCL signal) in order to bridge the undefined region of the falling edge of SCL.

<sup>4</sup>Measurements taken with 1 k  $\Omega$  pull-up resistor and 50 pF load.

<sup>5</sup> $C_b$  = total capacitance of one bus line in pF.

## 5.3. Parameter Measurement Information

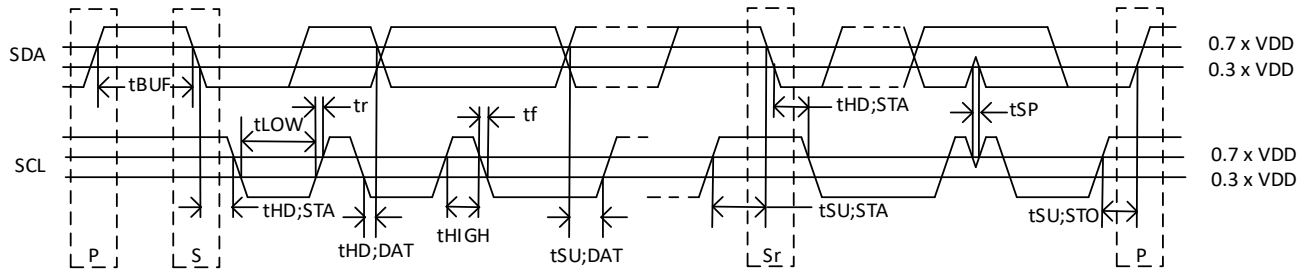

Figure 5.1 Definition of timing on I<sup>2</sup>C-bus

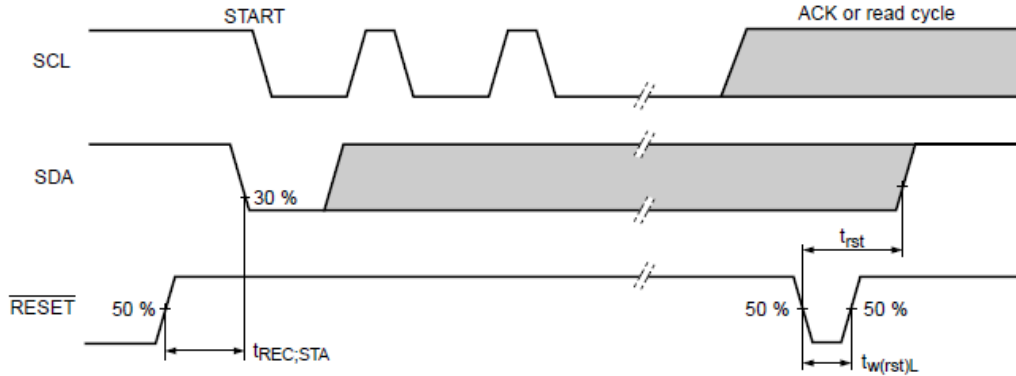

Figure 5.2 Definition of RESET timing

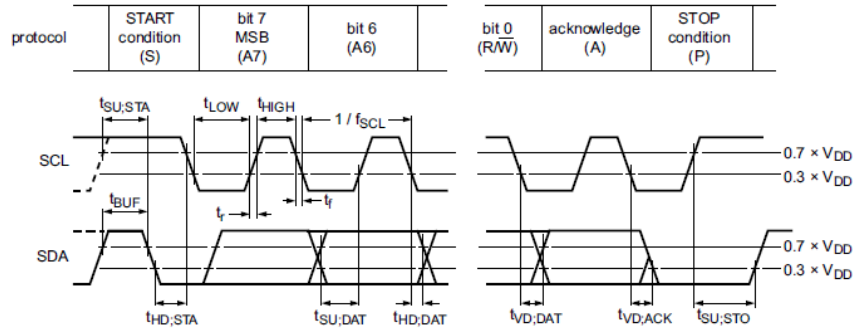
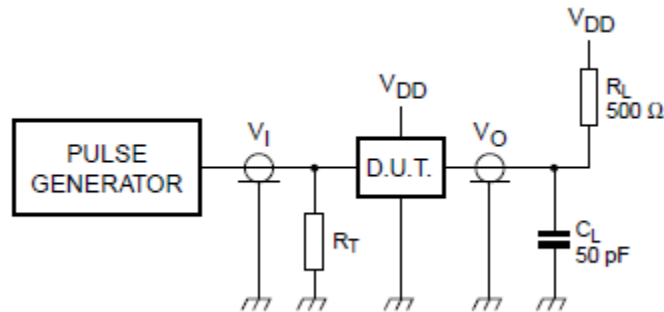

Figure 5.3 I<sup>2</sup>C-bus timing diagram



Definitions test circuit:

$R_L$  = Load resistance.

$C_L$  = Load capacitance including jig and probe capacitance.

$R_T$  = Termination resistance should be equal to the output impedance  $Z_o$  of the pulse generator.

Figure 5.4 Test circuitry for switching times

## 6. Detailed Description

### 6.1. Overview

The NCA9546 is a 4-channel, bidirectional translating I<sup>2</sup>C switch. The master SCL/SDA signal pair is directed to four channels of slave devices, SC0/SD0-SC3/SD3. Any individual downstream channel can be selected as well as any combination of the four channels.

The device offers an active-low  $\overline{\text{RESET}}$  input which resets the state machine and allows the NCA9546 to recover should one of the downstream I<sup>2</sup>C buses get stuck in a low state. The state machine of the device can also be reset by cycling the power supply, V<sub>CC</sub>, also known as a power-on reset (POR). Both the RESET function and a POR will cause all channels to be deselected.

The connections of the I<sup>2</sup>C data path are controlled by the same I<sup>2</sup>C master device that is switched to communicate with multiple I<sup>2</sup>C slaves. After the successful acknowledgment of the slave address (hardware selectable by A0, A1 and A2 terminals), a single 8-bit control register is written to or read from to determine the selected channels and state of the interrupts.

The NCA9546 may also be used for voltage translation, allowing the use of different bus voltages on each SCn/SDn pair such that 1.8-V, 2.5-V, or 3.3-V parts can communicate with 5-V parts. This is achieved by using external pull-up resistors to pull the bus up to the desired voltage for the master and each slave channel.



6.2. Functional Block Diagram

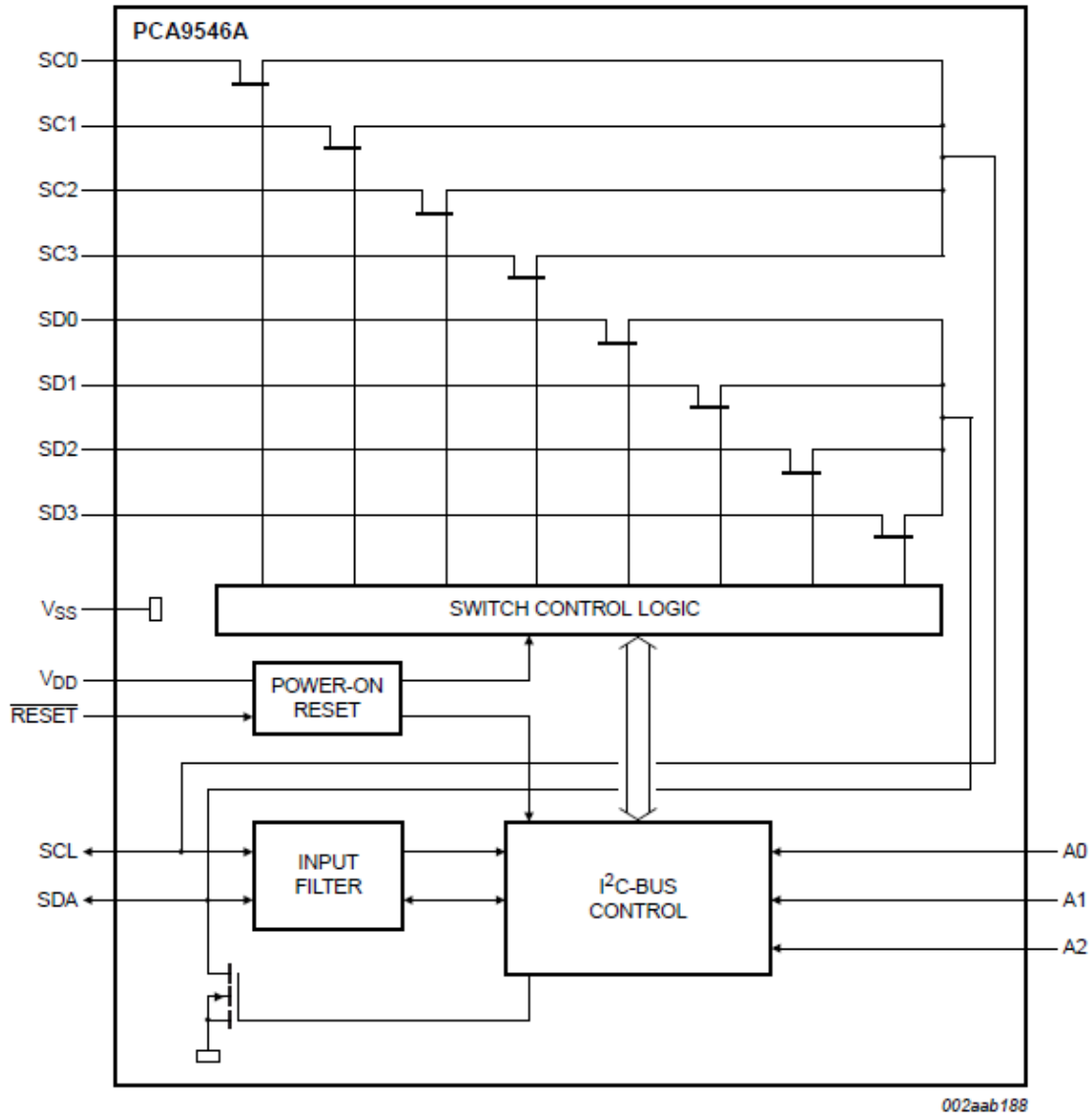

Figure 6.1 NCA9546 Functional block

6.3. Feature Description

The NCA9546 is a 4-channel, bidirectional translating switch for I<sup>2</sup>C buses that supports Standard-Mode (100 kHz) and Fast-Mode (400 kHz) operation. The NCA9546 features I<sup>2</sup>C control using a single 8-bit control register in which the four least significant bits control the enabling and disabling of the 4 switch channels of I<sup>2</sup>C data flow.

The NCA9546 also supports interrupt signals for each slave channel and this data is held in the four most significant bits of the control register. Depending on the application, voltage translation of the I<sup>2</sup>C bus can also be achieved using the NCA9546 to allow 1.8-V, 2.5-V, or 3.3-V parts to communicate with 5-V parts. Additionally, in the event that communication on the I<sup>2</sup>C bus enters a fault state, the NCA9546 can be reset to resume normal operation using the RESET pin feature or by a power-on reset which results from cycling power to the device.

6.4. Device Functional Modes

6.5. RESET Input

The RESET input can be used to recover the NCA9546 from a bus-fault condition. The registers and the I<sup>2</sup>C state machine within this device initialize to their default states if this signal is asserted low for a minimum of t<sub>WL</sub>.

All channels also are deselected in this case.  $\overline{\text{RESET}}$  must be connected to  $V_{CC}$  through a pull-up resistor.

**6.6. Power-On Reset**

When power is applied to  $V_{CC}$ , an internal power-on reset holds the NCA9546 in a reset condition until  $V_{CC}$  has reached  $V_{PORR}$ . At this point, the reset condition is released and the NCA9546 registers and I<sup>2</sup>C state machine are initialized to their default states, all zeroes, causing all the channels to be deselected. Thereafter,  $V_{CC}$  must be lowered below at least  $V_{PORF}$  to reset the device.

**6.7. Programming**

**6.8. I<sup>2</sup>C Interface**

The I<sup>2</sup>C bus is for two-way two-line communication between different ICs or modules. The two lines are a serial data line (SDA) and a serial clock line (SCL). Both lines must be connected to a positive supply via a pull-up resistor when connected to the output stages of a device. Data transfer can be initiated only when the bus is not busy.

One data bit is transferred during each clock pulse. The data on the SDA line must remain stable during the high period of the clock pulse, as changes in the data line at this time are interpreted as control signals (see Figure 6.1)

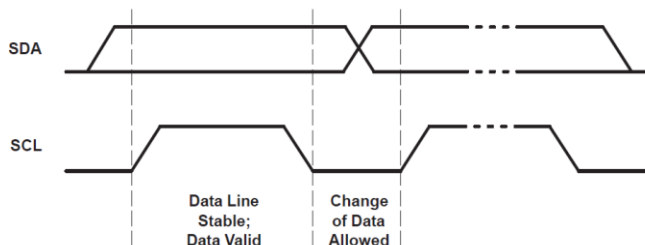

Figure 6.1 Bit Transfer

Both data and clock lines remain high when the bus is not busy. A high-to-low transition of the data line while the clock is high is defined as the start condition (S). A low-to-high transition of the data line while the clock is high is defined as the stop condition (P) (see Figure 6.2).

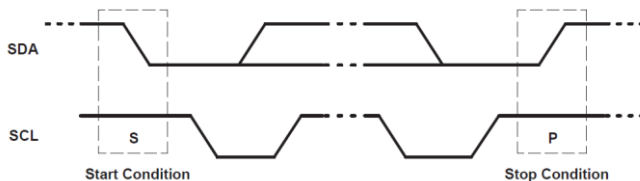

Figure 6.2 Definition of Start and Stop Conditions

A device generating a message is a transmitter; a device receiving a message is the receiver. The device that controls the message is the master, and the devices that are controlled by the master are the slaves (see Figure 6.3).

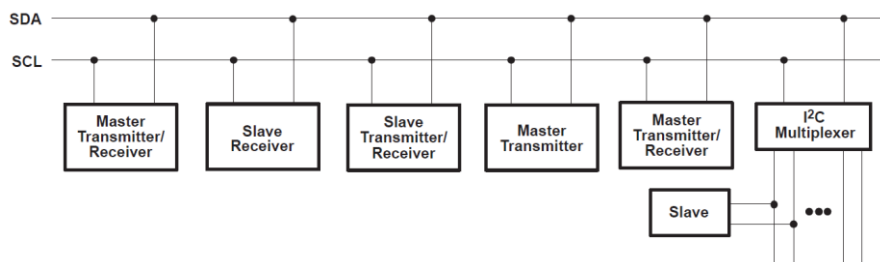

Figure 6.3 System Configuration

The number of data bytes transferred between the start and the stop conditions from transmitter to receiver is not limited. Each byte of eight bits is followed by one acknowledge (ACK) bit. The transmitter must release the SDA line before the receiver can send an ACK bit.

When a slave receiver is addressed, it must generate an ACK after the reception of each byte. Also, a master must generate an ACK after the reception of each byte that has been clocked out of the slave transmitter. The device that acknowledges

must pull down the SDA line during the ACK clock pulse so that the SDA line is stable low during the high pulse of the ACK-related clock period (see Figure 6.4). Setup and hold times must be taken into account.

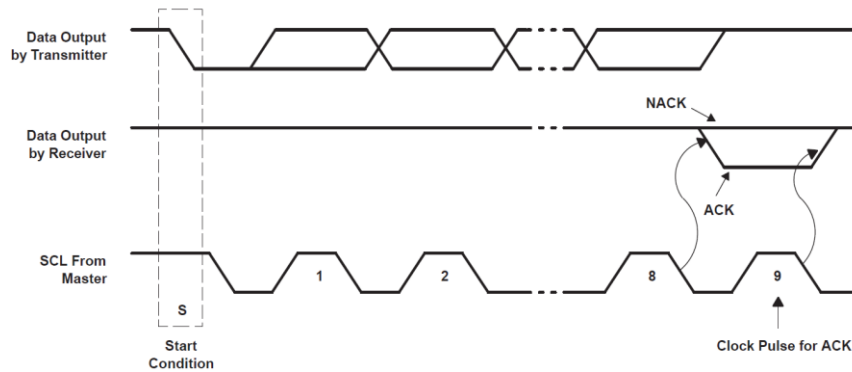

Figure 6.4 Acknowledgment on the I<sup>2</sup>C Bus

A master receiver must signal an end of data to the transmitter by not generating an acknowledge (NACK) after the last byte has been clocked out of the slave. This is done by the master receiver by holding the SDA line high. In this event, the transmitter must release the data line to enable the master to generate a stop condition. Data is transmitted to the NCA9546 control register using the write mode shown in Figure 6.5.

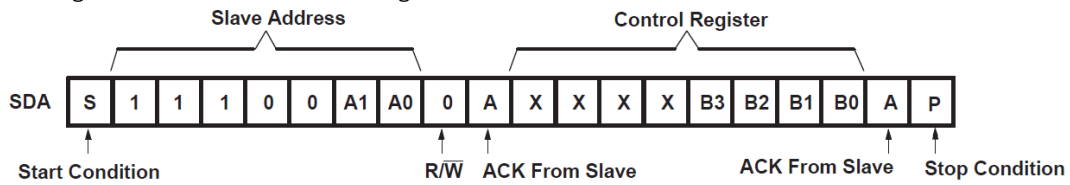

Figure 6.5 Write Control Register

Data is read from the NCA9546 control register using the read mode shown in Figure 6.6.

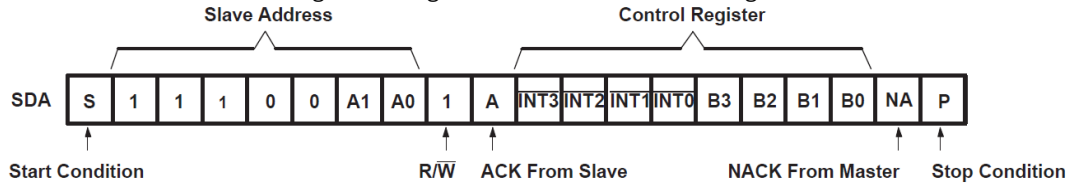

Figure 6.6 Read Control Register

**6.9. Control Register**

**6.10. Device Address**

Following a start condition, the bus master must output the address of the slave it is accessing. The address of the NCA9546 is shown in Figure 6.7 To conserve power, no internal pull-up resistors are incorporated on the hardware-selectable address terminals, and they must be pulled high or low.

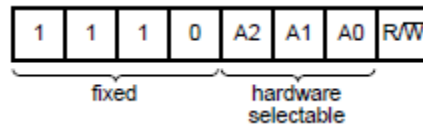

Figure 6.7 NCA9546 Address

The last bit of the slave address defines the operation to be performed. When set to a logic 1, a read is selected, while a logic 0 selects a write operation.

**6.11. Control Register Description**

Following the successful acknowledgment of the slave address, the bus master sends a byte to the NCA9546, which is stored in the control register (see Figure 6.8). If multiple bytes are received by the NCA9546, it saves the last byte received. This register can be written and read via the I<sup>2</sup>C bus.

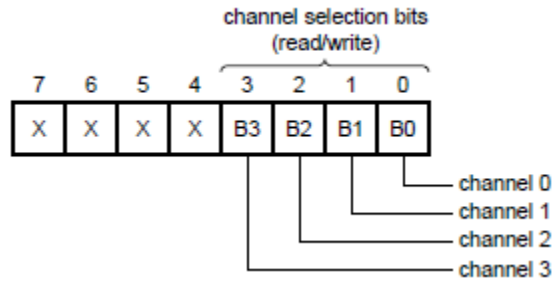

Figure 6.8 Control Register

### 6.12. Control Register Definition

One or several SCn/SDn downstream pairs, or channels, are selected by the contents of the control register (see Table 1). After the NCA9546 has been addressed, the control register is written. The four LSBs of the control byte are used to determine which channel or channels are to be selected. When a channel is selected, the channel becomes active after a stop condition has been placed on the I2C bus. This ensures that all SCn/SDn lines are in a high state when the channel is made active, so that no false conditions are generated at the time of connection. A stop condition must occur always right after the acknowledge cycle.

Table 1. Control Register Write (Channel Selection), Control Register Read (Channel Status)

INT3	INT2	INT1	INT0	B3	B2	B1	B0	COMMAND
X	X	X	X	X	X	X	0	Channel 0 disabled
							1	Channel 0 enabled
X	X	X	X	X	X	0	X	Channel 1 disabled
							1	Channel 1 enabled
X	X	X	X	X	0	X	X	Channel 2 disabled
							1	Channel 2 enabled
X	X	X	X	0	X	X	X	Channel 3 disabled
							1	Channel 3 enabled
0	0	0	0	0	0	X	0	No channel selected, power-up/reset default state

<sup>1</sup>Several channels can be enabled at the same time. For example, B3 = 0, B2 = 1, B1 = 1, B0 = 0 means that channels 0 and 3 are disabled, and channels 1 are 2 and enabled. Care should be taken not to exceed the maximum bus capacity.

## 7. Application and Implementation

Applications of the NCA9546 will contain an I<sup>2</sup>C (or SMBus) master device and up to four I<sup>2</sup>C slave devices. The downstream channels are ideally used to resolve I<sup>2</sup>C slave address conflicts. For example, if four identical digital temperature sensors are needed in the application, one sensor can be connected at each channel: 0, 1, 2, and 3. When the temperature at a specific location needs to be read, the appropriate channel can be enabled and all other channels switched off, the data can be retrieved, and the I<sup>2</sup>C master can move on and read the next channel.

In an application where the I<sup>2</sup>C bus will contain many additional slave devices that do not result in I<sup>2</sup>C slave address conflicts, these slave devices can be connected to any desired channel to distribute the total bus capacitance across multiple channels. If multiple switches will be enabled simultaneously, additional design requirements must be considered (See Design Requirements and Detailed Design Procedure).

### 7.1. Typical Application

A typical application of the NCA9546 will contain anywhere from 1 to 5 separate data pull-up voltages,  $V_{DPUX}$ , one for the master device ( $V_{DPUM}$ ) and one for each of the selectable slave channels ( $V_{DPU0} - V_{DPU3}$ ). In the event where the master device and all slave devices operate at the same voltage, then the pass voltage,  $V_{PASS} = V_{DPUX}$ . Once the maximum  $V_{PASS}$  is known,  $V_{CC}$  can be selected easily using Figure 7.2 In an application where voltage translation is necessary, additional design requirements must be considered (See Design Requirements).

Figure 7.1 shows an application in which the NCA9546 can be used.

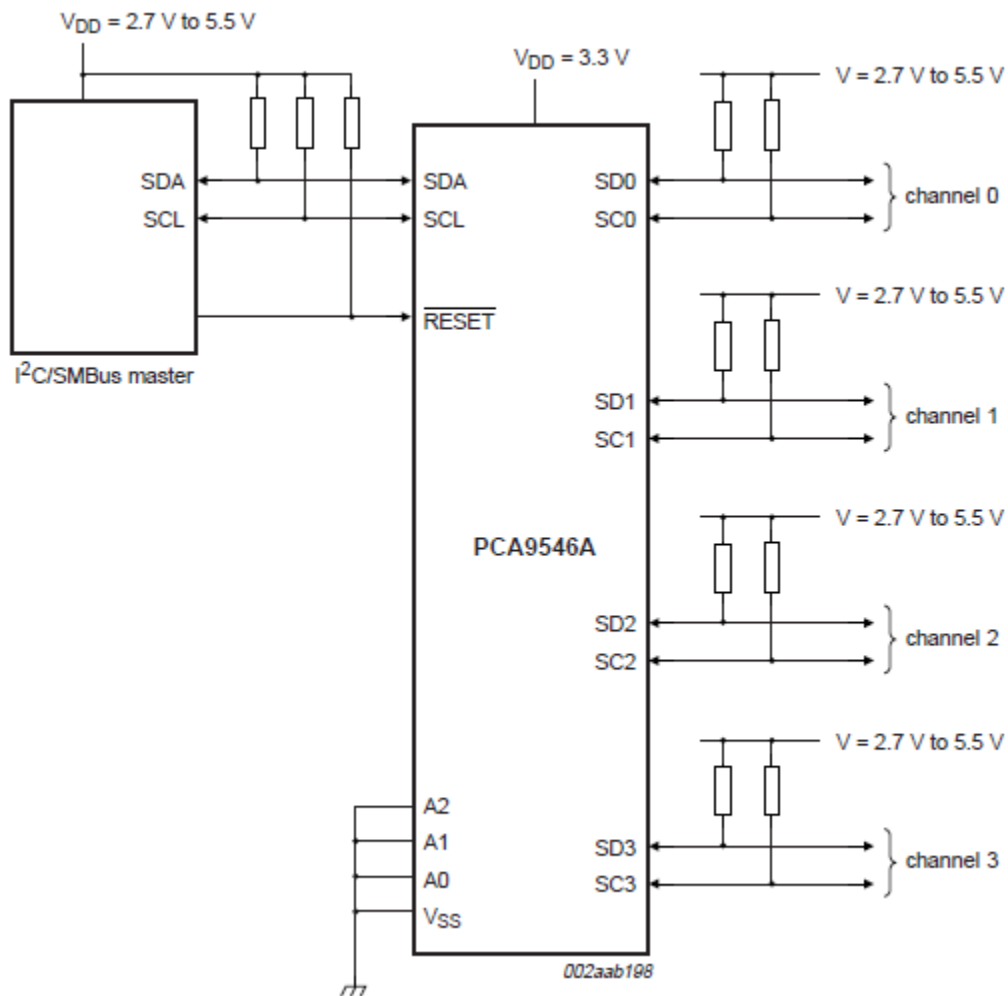

Figure 7.1 Typical Application Schematic

## 7.2. Design Requirements

The A0 and A1 terminals are hardware selectable to control the slave address of the NCA9546. These terminals may be tied directly to GND or VCC in the application.

If multiple slave channels will be activated simultaneously in the application, then the total  $I_{OL}$  from SCL/SDA to GND on the master side will be the sum of the currents through all pull-up resistors,  $R_p$ .

The pass-gate transistors of the NCA9546 are constructed such that the VCC voltage can be used to limit the maximum voltage that is passed from one I<sup>2</sup>C bus to another.

Figure 7.2 shows the voltage characteristics of the pass-gate transistors (note that the graph was generated using data specified in the Electrical Characteristics section of this data sheet). In order for the NCA9546 to act as a voltage translator, the  $V_{pass}$  voltage must be equal to or lower than the lowest bus voltage. For example, if the main bus is running at 5 V and the downstream buses are 3.3 V and 2.7 V,  $V_{pass}$  must be equal to or below 2.7 V to effectively clamp the downstream bus voltages. As shown in Figure 7.2,  $V_{pass(max)}$  is 2.7 V when the NCA9546A supply voltage is 4 V or lower, so the NCA9546A supply voltage could be set to 3.3 V. Pull-up resistors then can be used to bring the bus voltages to their appropriate levels (see Figure 7.1).

## 7.3. Detailed Design Procedure

Once all the slaves are assigned to the appropriate slave channels and bus voltages are identified, the pull-up resistors,  $R_p$ , for each of the buses need to be selected appropriately. The minimum pull-up resistance is a function of  $V_{DPUV}$ ,  $V_{OL(max)}$ , and  $I_{OL}$ :

$$R_{p(min)} = \frac{V_{DPUV} - V_{OL(max)}}{I_{OL}} \quad (1)$$

The maximum pull-up resistance is a function of the maximum rise time,  $t_r$  (300 ns for fast-mode operation,  $f_{SCL} = 400$  kHz) and bus capacitance,  $C_b$ :

$$R_{p(max)} = \frac{t_r}{0.8473 \times C_b} \quad (2)$$

The maximum bus capacitance for an I<sup>2</sup>C bus must not exceed 400 pF for fast-mode operation. The bus capacitance can be approximated by adding the capacitance of the NCA9546,  $C_{io(OFF)}$ , the capacitance of wires/connections/traces, and the capacitance of each individual slave on a given channel. If multiple channels will be activated simultaneously, each of the slaves on all channels will contribute to total bus capacitance.

## 7.4. NCA9546 Application Curves

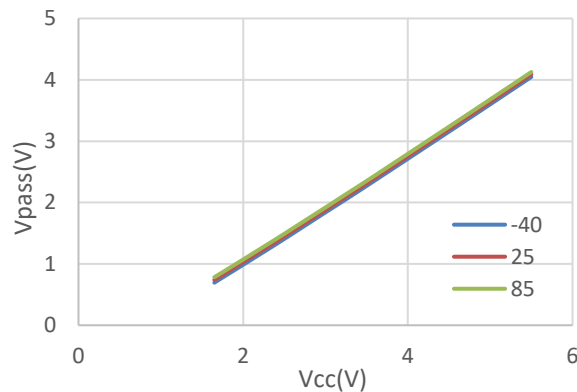
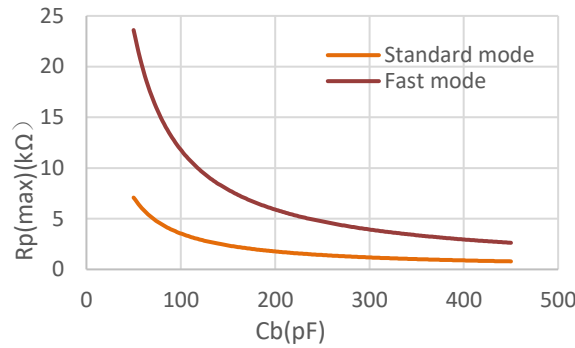
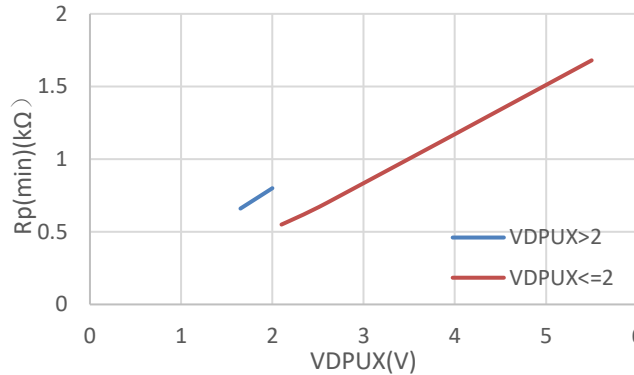

Figure 7.2 Pass-Gate Voltage ( $V_{pass}$ ) vs Supply Voltage ( $V_{CC}$ ) at Three Temperature Points



Standard mode (f<sub>scl</sub>=100kHz, t<sub>r</sub>=1μs); Fast mode: (f<sub>scl</sub>=400kHz, t<sub>r</sub>=300ns)  
 Figure 7.3 Maximum Pull-Up resistance (R<sub>p(max)</sub>) vs Bus Capacitance (C<sub>b</sub>)



V<sub>OL</sub>=0.2\*V<sub>DPUX</sub>, I<sub>OL</sub>=2mA when V<sub>DPUX</sub>≤2V; V<sub>OL</sub>=0.4V, I<sub>OL</sub>=3mA when V<sub>DPUX</sub>>2V  
 Figure 7.4 Minimum Pull-Up resistance (R<sub>p(min)</sub>) vs Pull-up reference voltage (V<sub>DPUX</sub>)

## 8. Layout

### 8.1. Layout Guidelines

For PCB layout of the NCA9546, common PCB layout practices should be followed but additional concerns related to high-speed data transfer such as matched impedances and differential pairs are not a concern for I<sup>2</sup>C signal speeds. It is common to have a dedicated ground plane on an inner layer of the board and terminals that are connected to ground should have a low-impedance path to the ground plane in the form of wide polygon pours and multiple vias. By-pass and de-coupling capacitors are commonly used to control the voltage on the VCC terminal, using a larger capacitor to provide additional power in the event of a short power supply glitch and a smaller capacitor to filter out high-frequency ripple.

In an application where voltage translation is not required, all V<sub>DPUX</sub> voltages and VCC could be at the same potential and a single copper plane could connect all of pull-up resistors to the appropriate reference voltage. In an application where voltage translation is required, V<sub>DPUM</sub>, V<sub>DPU0</sub>, V<sub>DPU1</sub>, V<sub>DPU2</sub>, and V<sub>DPU3</sub> may all be on the same layer of the board with split planes to isolate different voltage potentials.

To reduce the total I2C bus capacitance added by PCB parasitics, data lines (S<sub>Cn</sub>, S<sub>Dn</sub> and I<sub>NTn</sub>) should be as short as possible and the widths of the traces should also be minimized (e.g. 5-10 mils depending on copper weight).

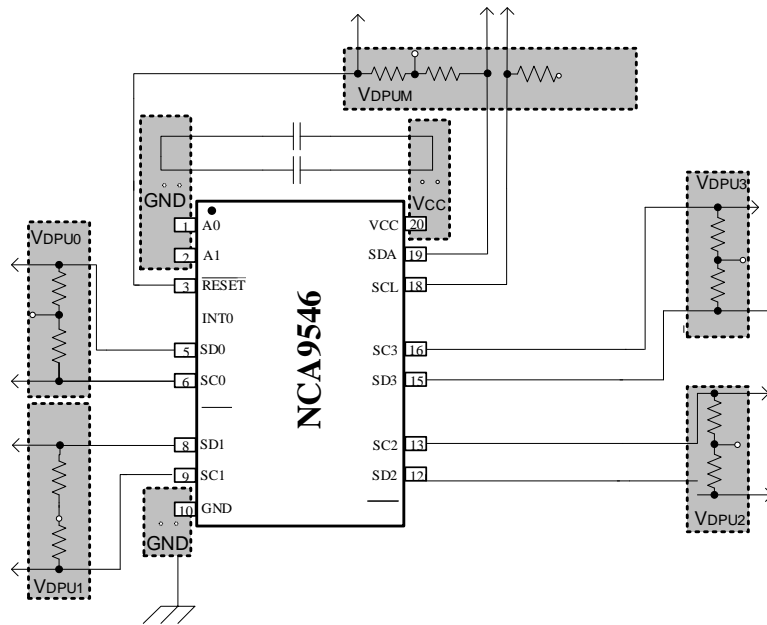
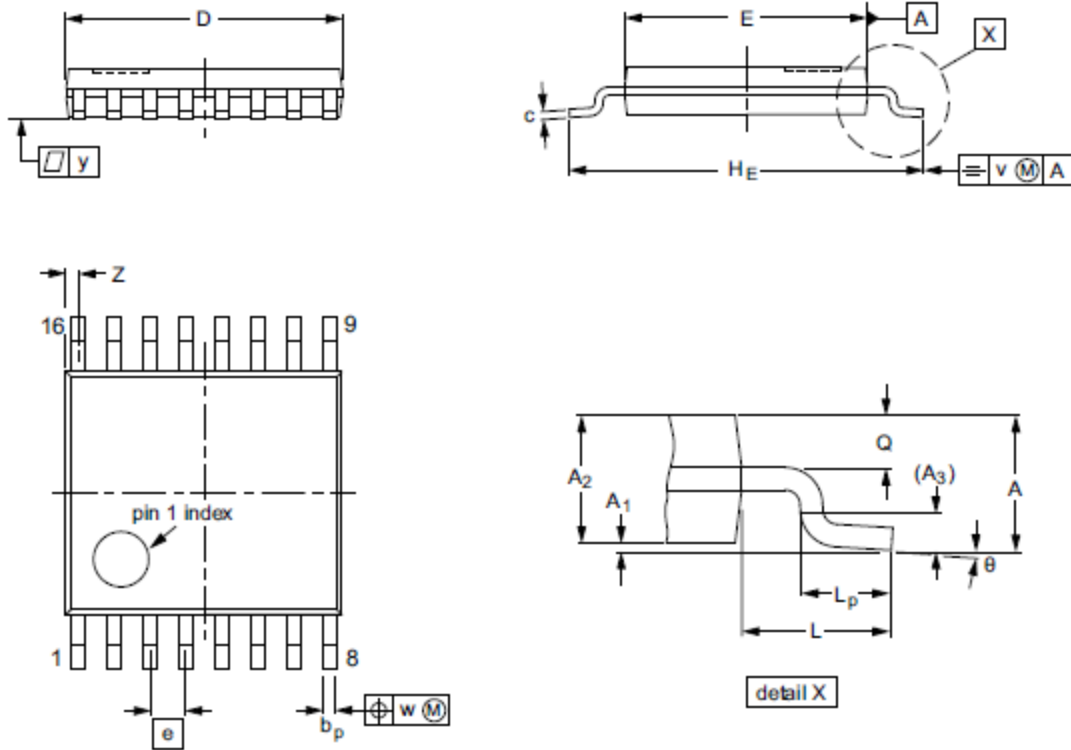

Figure 8.1 Typical Application PCB



### 9. Package Information



DIMENSIONS (mm are the original dimensions)

UNIT	A max.	A <sub>1</sub>	A <sub>2</sub>	A <sub>3</sub>	b <sub>p</sub>	c	D <sup>(1)</sup>	E <sup>(2)</sup>	e	H <sub>E</sub>	L	L <sub>p</sub>	Q	v	w	y	z <sup>(1)</sup>	θ
mm	1.1	0.15 0.05	0.95 0.80	0.25	0.30 0.19	0.2 0.1	5.1 4.9	4.5 4.3	0.65	6.6 6.2	1	0.75 0.50	0.4 0.3	0.2	0.13	0.1	0.40 0.06	8° 0°

Figure 9.1 Package outline for TSSOP16

### 10. Order information

Part Number	Pins	Temperature	MSL	Package Type	Package Drawing	Package Qty
NCA9546-DTSPR	16	-40 to 105°C	2	TSSOP16	TSSOP	3000

### 11. Documentation Support

Part Number	Product Folder	Datasheet	Technical Documents	Isolator selection guide
NCA9546	<a href="#">Click here</a>	<a href="#">Click here</a>	<a href="#">Click here</a>	<a href="#">Click here</a>

### 12. Tape and Reel Information

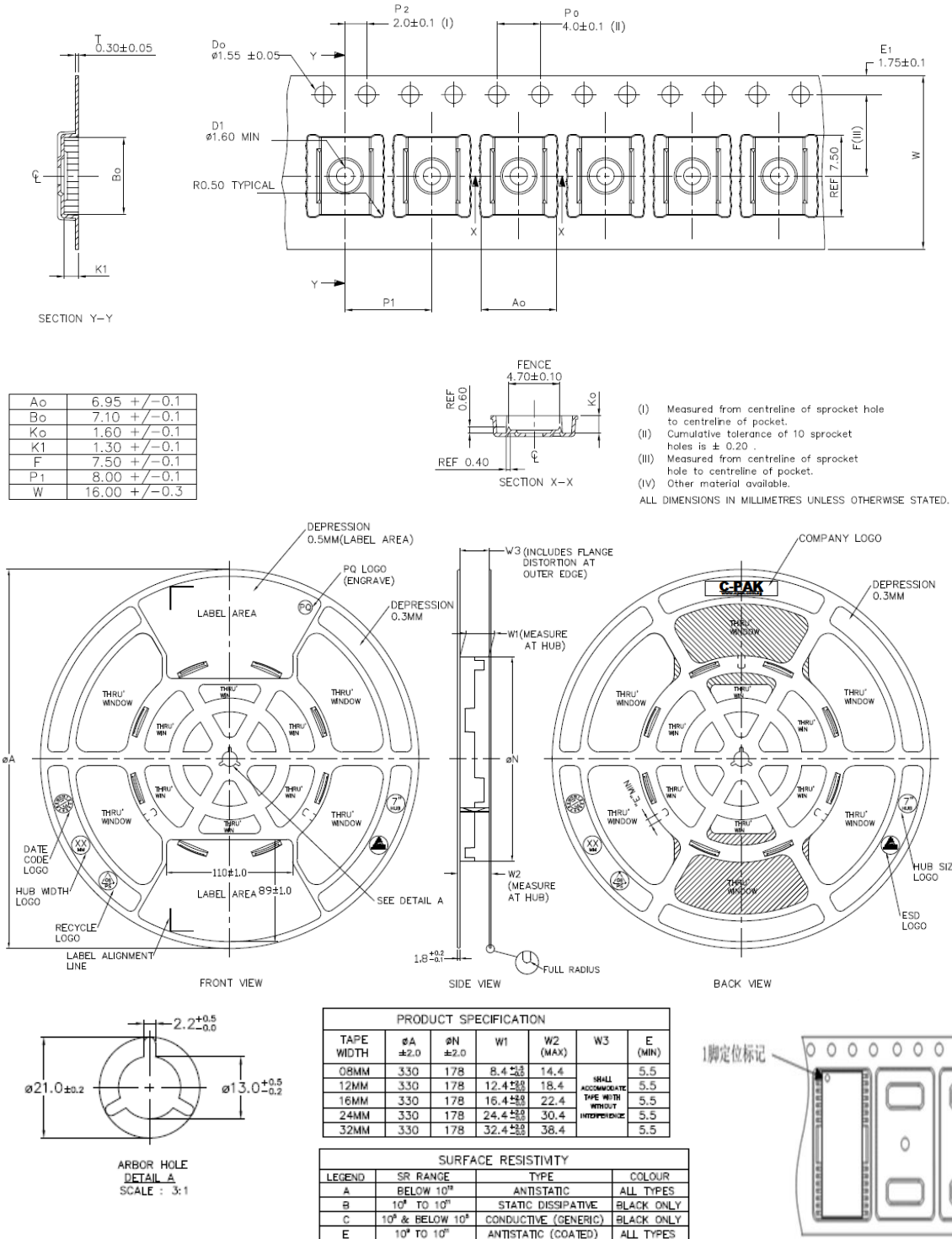

Figure 12.1 Tape and Reel Information of TSSOP

### 13. Revision History

Revision	Description	Date
1.0	Initial version	2021/4/2
1.1	Supply voltage range changed	2021/11/11