

BSBC7 Series DC Contactor Specification

Customer	General Specification
Product Name	DC Contactor
Part Number	BSBC7-100T-12 BSBC7-100TH-12 BSBC7-100TC-12 BSBC7-100T-24 BSBC7-100TH-24 BSBC7-100TC-24 BSBC7-100T-12W BSBC7-100TH-12W BSBC7-100TC-12W BSBC7-100T-24W BSBC7-100TH-24W BSBC7-100TC-24W BSBC7-100T-P BSBC7-100TH-P BSBC7-100TC-P
Date	2022/04/01
Validity	2 Year
Version	2022V1.0

Feature

- Safe:** Fully sealed with epoxy resin, contact and coil will not be oxidized, product performance is not affected by external environment, no arc outbursts, can be worked in explosive and harmful environment.
- Reliable:** Adopt DC high voltage non-polarity design, the breaking capacity is higher and more reliable, convenient and reliable installation or wiring.
- Good for environment:** All components meet the latest ROHS environmental requirements.
- Application :** Ordinary, quick charging, auxiliary contactor. Can be used in EV, charging equipment, photovoltaic system, etc.
- Approval:** UL, CE, TUV

Ordering

BSBC7-100 T H -12 W /XXX

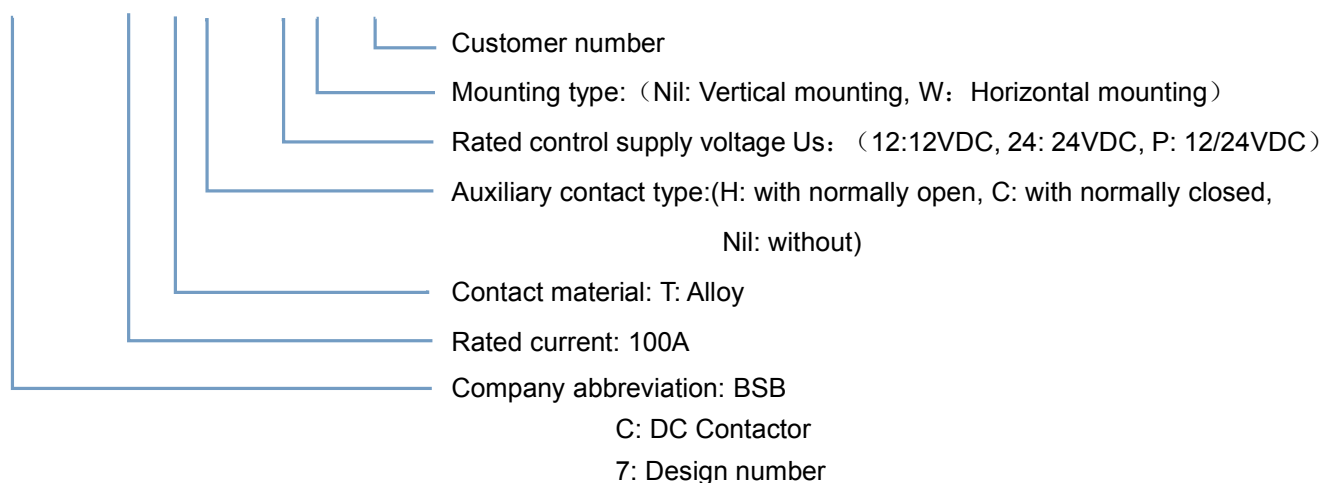

Basic Parameter

Contact parameter			Coil parameter			
Main contact	Rated operational current Ie	100A	Product type		Standard	Energy-saving
	Rated operational voltage Ue	12~1000VDC	Rated voltage Us(VDC)	12	24	12/24
	Min. load	1A12VDC	Operating voltage range (VDC)	9~16	18~32	8~36
	Main contact type	1SH (SPST NO DM)	Pick up voltage (VDC)	≤9	≤18	7~8
	Nominal resistance of main circuit	0.4 mΩ (@100A)	Release voltage (VDC)	1.2~3.6	2.4~7.2	5~6
	Main contact mounting	M5 internal thread	Coil power	5.5W	6W	holding: 1.6W
	Connecting torque	3~4N·m	Inrush current	0.46A	0.25A	2A (0.1s)
	Max. switching current (more than one cycle)	1000A320VDC	Holding current	0.46A	0.25A	0.133A@12V 0.067A@24V
			Pick up time (@Us)	≤30ms		≤45ms
Auxiliary contact	Max. current	30VDC 0.8A	Release time (@Us)	≤10ms		
	Min. current	8VDC 100mA	Bounce time (@Us)	≤5ms		
	Contact resistance	<0.15Ω				

Note: The above parameters are normal temperature rating, if other parameters needed, can customize.

Life characteristics		
Mechanical Life	300,000 cycles	
Resistivity load life (L/R≤1ms)	See next page	
Capacitive load life (RC=1ms , only for connecting)	250A	50,000 cycles
Note: For capacitive load life, when the contactor is used to control the main circuit of charge and discharge, the pre-charge circuit should be added. If there is no pre-charging path, a transient large current will be generated when the contactor closes, which may cause the contactor to stick.		

Environmental characteristics		
Shock	Stability test	196m/s ² (20G)
	Strength test	490m/s ² (50G)
Resistance to vibration		10~1000Hz, 10G
Operating ambient temperature		-40℃~+85℃
Operating ambient humidity		5%~85% RH
IP Grade		IP67(inner space)
Altitude		≤4000m

Electrical characteristics	
Dielectric withstand voltage	DC3110V / AC2200V
Insulation resistance	≥1000MΩ@1000VDC
Nominal insulation voltage Ui	1000V

Other	
Weight	Standard: 190g, with auxiliary 195g Energy-saving: 205g, with auxiliary 210g
The cross sectional area of an external conductor	≥35mm ²
Case mounting hole torque	MAX 2.3 N·m

Short overload capacity curve

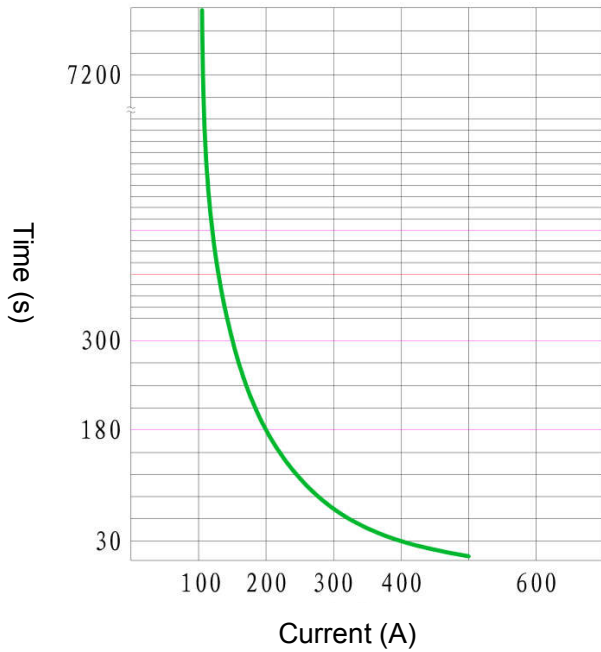

Cut-off life curve of resistive load

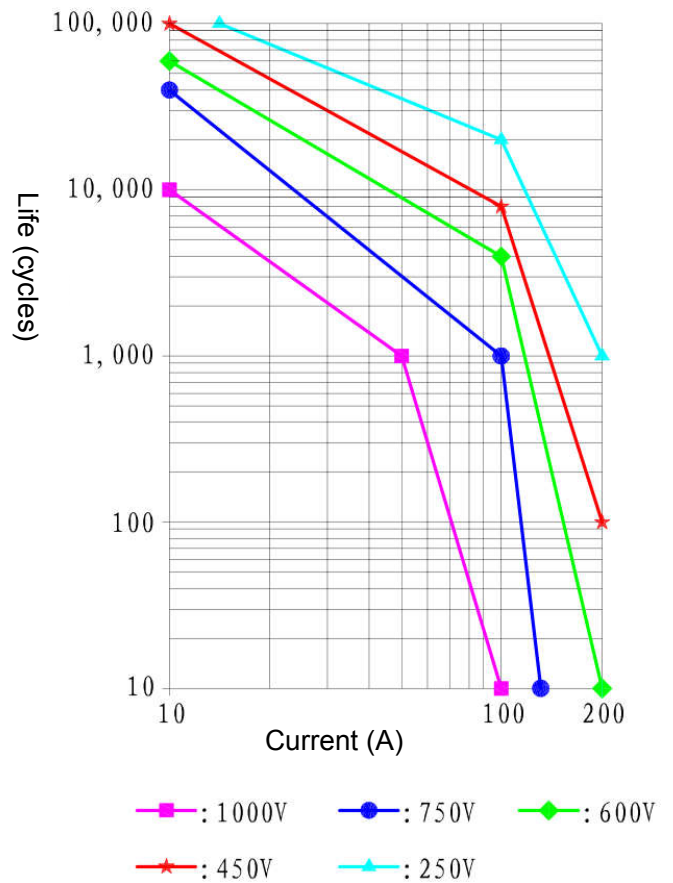

Note: Except for special note, the ambient temperature of electrical durability test is 23°C, and the on-break ratio is: 1s: 9s

Outline and wiring schematic diagram

Standard

Vertical mounting structure:

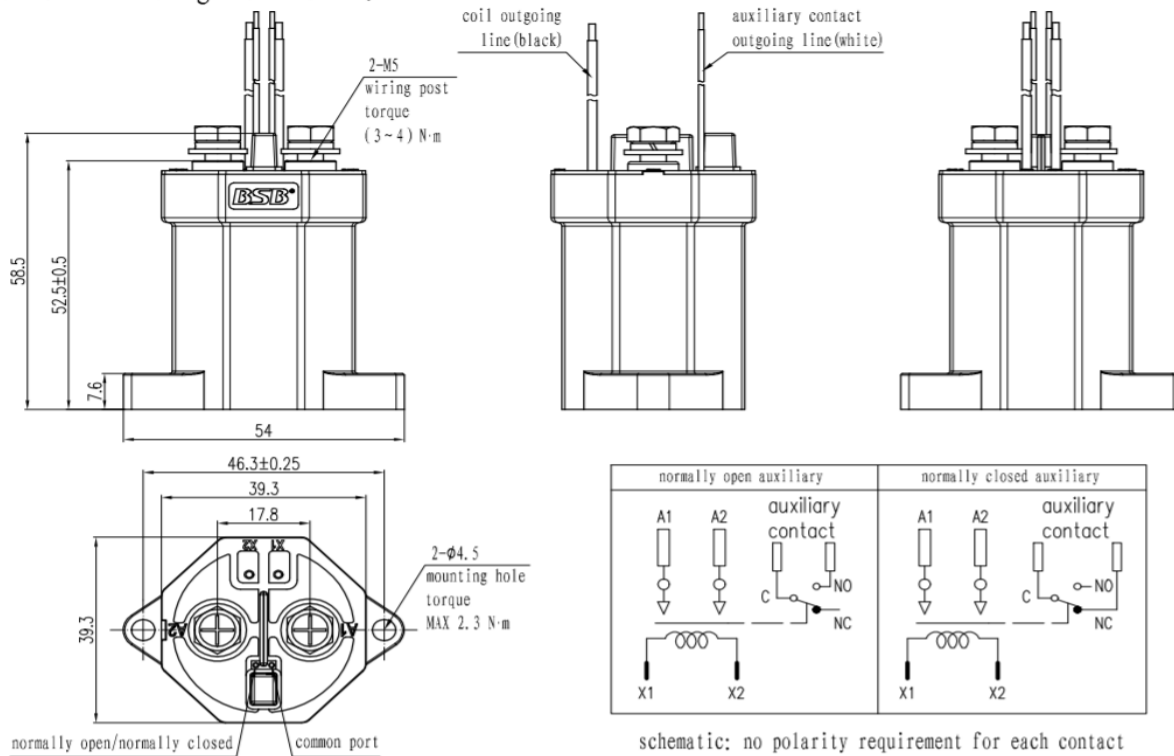

Horizontal mounting structure:

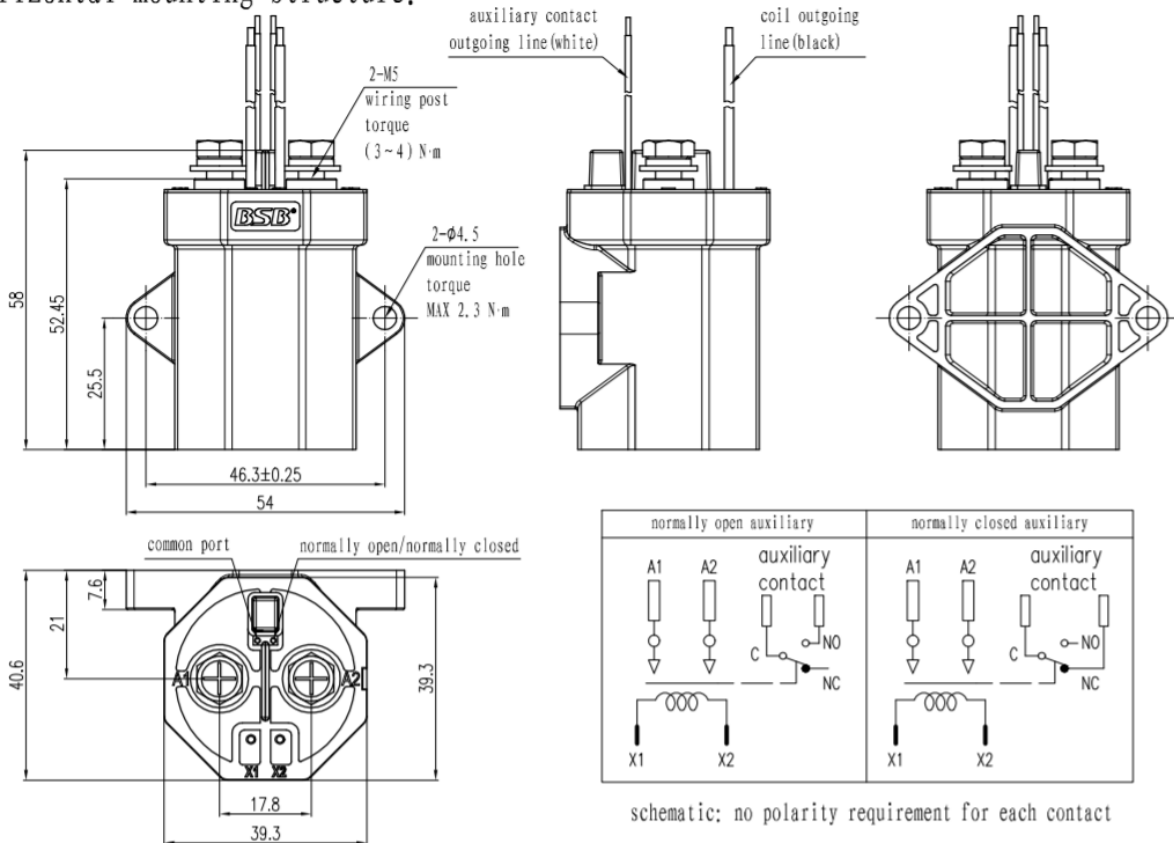

Energy-saving

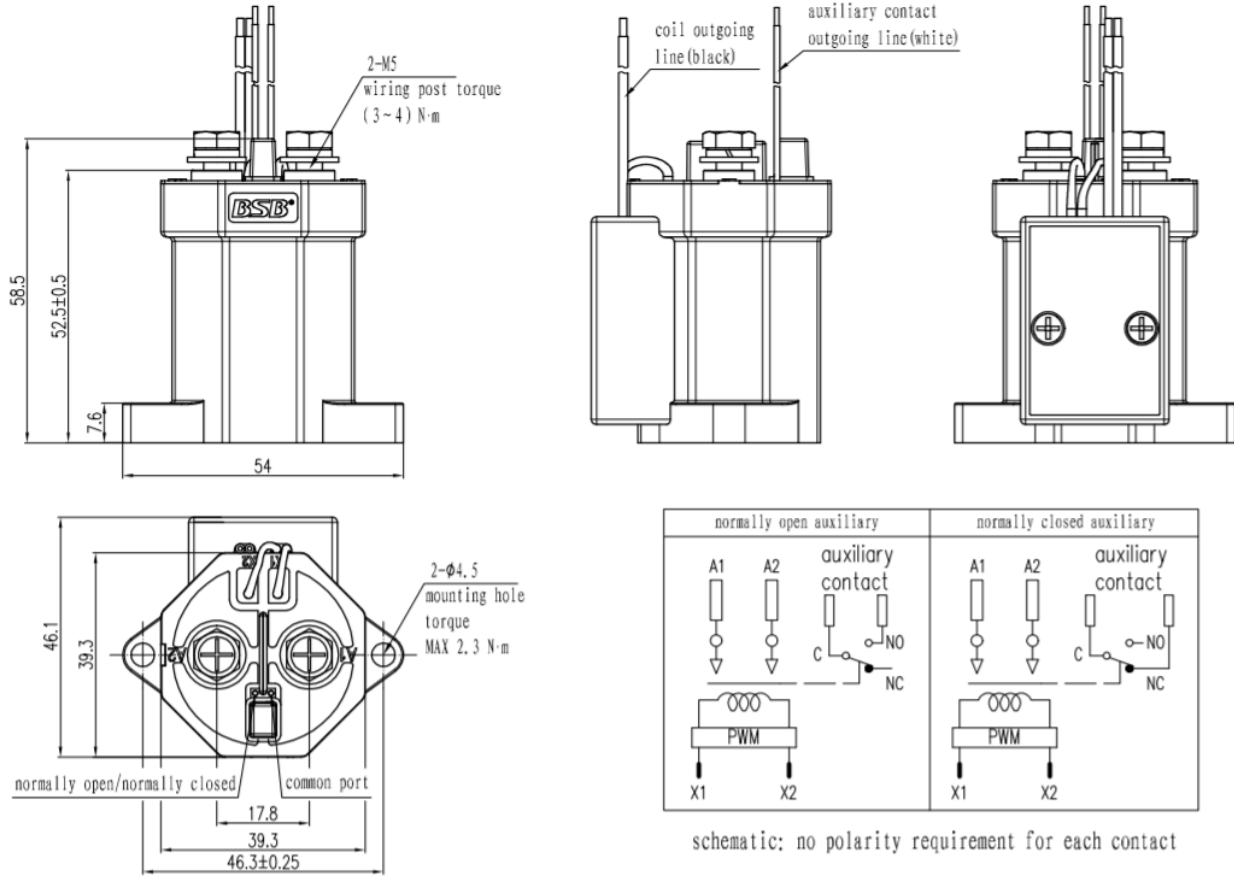

Note: Control coil wire length 300±20mm

Product without tolerance, when ≤10mm, tolerance ±0.3mm

When dimension between 10~50 mm, tolerance ±0.5mm

When dimension ≥50mm, tolerance ±0.8mm