



WINSTAR Display Co.,Ltd.
華凌光電股份有限公司



Winstar Display Co., LTD

華凌光電股份有限公司

WEB: <https://www.winstar.com.tw> E-mail: sales@winstar.com.tw



SPECIFICATION

CUSTOMER : _____

MODULE NO.: WF57A4TLAFDNT0#

<p style="text-align: center;">APPROVED BY:</p> <p>(FOR CUSTOMER USE ONLY)</p>	<p>PCB VERSION: _____</p> <p>DATA: _____</p>
---	--

SALES BY	APPROVED BY	CHECKED BY	PREPARED BY
			葉虹蘭
ISSUED DATE: 2024/04/24			

TFT Display Inspection Specification: <https://www.winstar.com.tw/technology/download.html>

Precaution in use of TFT module: <https://www.winstar.com.tw/technology/download/declaration.html>



RECORDS OF REVISION

DOC. FIRST ISSUE

VERSION	DATE	REVISED PAGE NO.	SUMMARY
0	2023/12/25		First issue
A	2024/04/24		Add interface

Contents

- 1.Module Classification Information
- 2.Summary
- 3.General Specifications
- 4.Absolute Maximum Ratings
- 5.Electrical Characteristics
- 6.Timing Characteristics
- 7.Optical Characteristics
- 8.Interface
- 9.Block Diagram
- 10.Reliability
- 11.Touch Panel Information
- 12.Contour Drawing
- 13.Other

1. Module Classification Information

W F 57 A4 T L A F D N T 0 #
 ① ② ③ ④ ⑤ ⑥ ⑦ ⑧ ⑨ ⑩ ⑪ ⑫ ⑬

①	Brand : WINSTAR DISPLAY CORPORATION											
②	Display Type : F→TFT Type, J→Custom TFT											
③	Display Size : 5.7" TFT											
④	Model serials no.											
⑤	Backlight Type :	F→CCFL, White S→LED, High Light White					T→LED, White Z→Nichia LED, White					
⑥	LCD Polarize Type/ Temperature range/ Gray Scale Inversion Direction	A→Transmissive, N.T, IPS TFT C→Transmissive, N. T, 6:00 ; F→Transmissive, N.T,12:00 ; I→Transmissive, W. T, 6:00 K→Transflective, W.T,12:00 L→Transmissive, W.T,12:00 N→Transmissive, Super W.T, 6:00					Q→Transmissive, Super W.T, 12:00 R→Transmissive, Super W.T, O-TFT V→Transmissive, Super W.T, VA TFT W→Transmissive, Super W.T, IPS TFT X→Transmissive, W.T, VA TFT Y→Transmissive, W.T, IPS TFT Z→Transmissive, W.T, O-TFT					
⑦	A : TFT LCD B : TFT+SCREW HOLES+CONTROL BOARD C : TFT+ SCREW HOLES +A/D BOARD D : TFT+ SCREW HOLES +A/D BOARD+CONTROL BOARD E : TFT+ SCREW HOLES +POWER BOARD					F : TFT+CONTROL BOARD G : TFT+ SCREW HOLES H : TFT+D/V BOARD I : TFT+ SCREW HOLES +D/V BOARD J : TFT+POWER BD						
⑧	Resolution:											
	A	128160	B	320234	C	320240	D	480234	E	480272	F	640480
	G	800480	H	1024600	I	320480	J	240320	K	800600	L	240400
	M	1024768	N	128128	P	1280800	Q	480800	R	640320	S	480128
	T	800320	U	8001280	V	176220	W	1280398	X	1024250	Y	1920720
	Z	800200	2	1024324	3	7201280	4	19201200	5	1366768	6	1280320
⑨	D: Digital L : LVDS M:MIPI											
⑩	Interface:											
	N	Without control board			A	8Bit		B	16Bit		H	HDMI
	I	I2C Interface			R	RS232		S	SPI Interface		U	USB
⑪	TS:											
	N	Without TS			T	Resistive touch panel			C	Capacitive touch panel (G-F-F)		
	G	Capacitive touch panel (G-G)					C1	Capacitive touch panel (G-F-F)+OCA				
	C2	Capacitive touch panel (G-F-F)+OCR					G1	Capacitive touch panel (G-G)+OCA				
	G2	Capacitive touch panel (G-G)+OCR					B	CTP+GG+USB				
⑫	Version: X:Raspberry pi											
⑬	Special Code	#:Fit in with ROHS directive regulations										

2.Summary

TFT 5.7" is a color TFT LCD supplied by Winstar. This main Panel has an 5.7 inch diagonally measured active display area with 640 x RGB x 480 resolution. TFT 5.7" has been designed to apply the interface method that enables low power, high speed, and high contrast. The TFT 5.7" is intended to support applications where thin thickness, wide viewing angle, low power are critical factors and graphic displays are important.

3.General Specifications

Item	Dimension	Unit
Size	5.7	inch
Dot Matrix	640 x RGB x 480(TFT)	dots
Module dimension	125.0 x 98.8 x 9.0	mm
Active area	115.2 x 86.4	mm
Pixel pitch	0.18 x 0.18	mm
LCD type	TFT, Normally White, Transmissive	
View Direction	6 o'clock	
Gray Scale Inversion Direction	12 o'clock	
Aspect Ratio	4:3	
Drive IC	HX8250+HX8678	
TFT interface	18-bit RGB	
Backlight Type	LED ,Normally White	
With /Without TP	With RTP	
Surface	Anti-Glare	

*Color tone slight changed by temperature and driving voltage.

4. Absolute Maximum Ratings

Item	Symbol	Min	Typ	Max	Unit
Operating Temperature	TOP	-20	—	+70	°C
Storage Temperature	TST	-30	—	+80	°C

Note: Device is subject to be damaged permanently if stresses beyond those absolute maximum ratings listed above

1. Temp. 60°C, 90% RH MAX. Temp. > 60°C, Absolute humidity shall be less than 90% RH at 60°C

5. Electrical Characteristics

5.1. Operating conditions:

Item	Symbol	Condition	Min	Typ	Max	Unit
Supply Voltage For LCM	VCC	—	3.0	3.3	3.6	V
Supply Current For LCM	ICC	-	—	9	—	mA
Power Consumption	-	-	—	29.7	—	mW
Power Supply for Analog	AVDD	AVDD-AGND	—	9.6	—	V
Input Voltage	VIH	H Level	0.7VCC	—	VCC	V
	VIL	L Level	0	—	0.3VCC	V
Recommended LC Driving Voltage for 25°C	VGH	(Note)	15.5	16	16.5	V
	VGL		-5.5	-6	-6.5	V
	VCOM		—	3.8	—	V

Note 1 : This value is test for VDD=3.3V , Ta=25 °C only

(1) VGH is TFT Gate on operating Voltage.

(2) VGH is TFT Gate off operating Voltage ,VGL signal must be fluctuates with same phase as VCOM

when Storage on Gate structure.

(3) VCOM must be adjusted to optimize display quality Crosstalk , Contrast Ratio and etc

5.2. LED driving conditions

Parameter	Symbol	Min.	Typ.	Max.	Unit	Remark
LED current	-	-	60	-	mA	-
Power Consumption	-	-	1386	1470	mW	-
LED voltage	VBL+	18.9	23.1	24.5	V	Note 1
LED Life Time	-	-	50,000	-	Hr	Note 2,3,4

Note 1 : There are 1 Groups LED

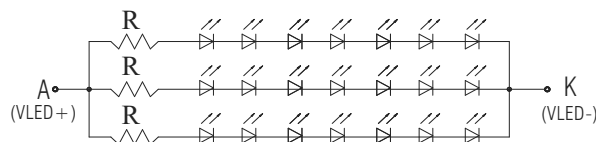

Back Light Circuit

Note 2 : Ta = 25 °C

Note 3 : Brightness to be decreased to 50% of the initial value

Note 4 : The single LED lamp case

6. Timing Characteristics

6.1. AC Timing Characteristics

Please refer to the IC SPEC :(Himax) HX8250-A01B
(Himax) HX8678-A000

6.2. Power ON/OFF Sequence

To prevent the device damage from latch up, the power ON/OFF sequence shown below must be followed.

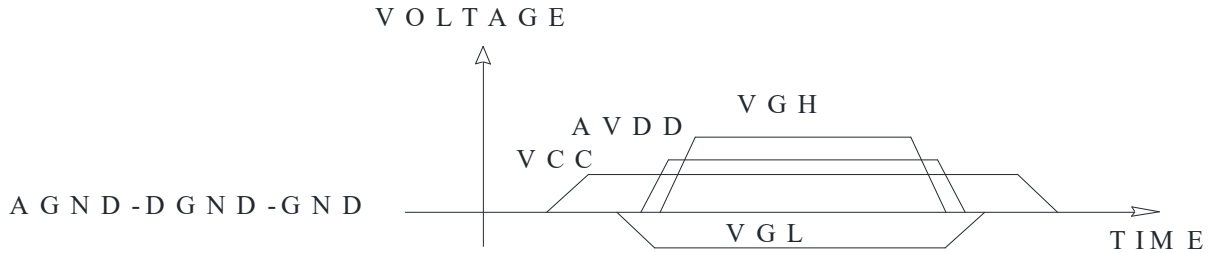

(Note) Display Direction of the panel

The UD and LR control the Display direction of the panel.

The settings of UD and LR are or following:



(1) UD=VCC and LR=DGND



(2) UD=VCC and LR=VCC



(3) UD= DGND and LR=DGND



(4) UD= DGND and LR= VCC

7. Optical Characteristics

Item	Symbol	Condition.	Min	Typ.	Max.	Unit	Remark	
Response time	Tr	$\theta=0^\circ$ 、 $\Phi=0^\circ$	-	10	20	ms	Note 3	
	Tf		-	15	30			
Contrast ratio	CR	At optimized viewing angle	200	300	-	-	Note 4	
Color Chromaticity	White	$\theta=0^\circ$ 、 $\Phi=0^\circ$	Wx	0.264	0.314	0.364	-	Note 2,6,7
			Wy	0.295	0.345	0.395	-	
Viewing angle (Gray Scale Inversion Direction)	Hor.	$CR \geq 10$	Θ_R	-	70	-	Deg.	Note 1
			Θ_L	-	70	-		
	Ver.		Φ_T	-	60	-		
			Φ_B	-	50	-		
Brightness	-	-	250	350	-	cd/m ²	Center of display	
Uniformity	(U)	-	75	-	-	%	Note 5	

Ta=25±2°C

Note 1: Definition of viewing angle range

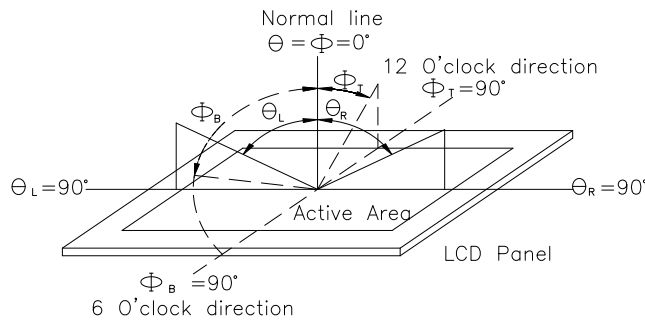

Fig 7.1. Definition of viewing angle

Note 2: Test equipment setup:

After stabilizing and leaving the panel alone at a driven temperature for 10 minutes, the measurement should be executed. Measurement should be executed in a stable, windless, and dark room. Optical specifications are measured by Topcon BM-7 or BM-5 luminance meter 1.0° field of view at a distance of 50cm and normal direction.

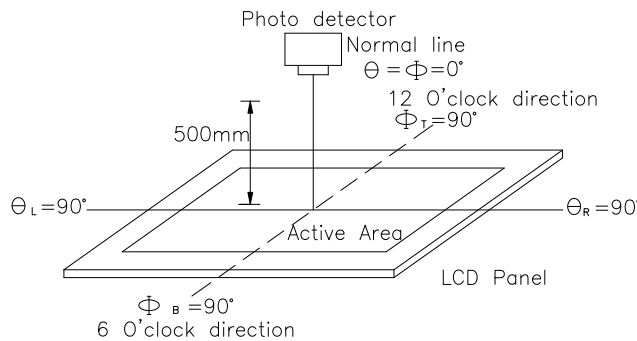
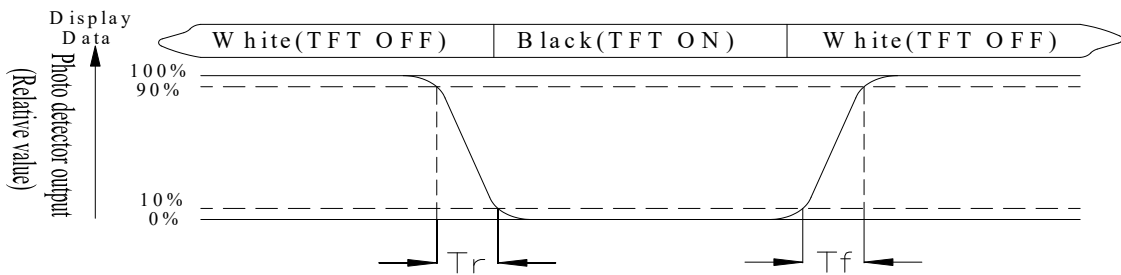

Fig 7.2. Optical measurement system setup

Note 3: Definition of Response time:

The response time is defined as the LCD optical switching time interval between “White” state and “Black” state. Rise time, T_r , is the time between photo detector output intensity changed from 90% to 10%. And fall time, T_f , is the time between photo detector output intensity changed from 10% to 90%



Note 4: Definition of contrast ratio:

The contrast ratio is defined as the following expression.

$$\text{Contrast ratio (CR)} = \frac{\text{Luminance measured when LCD on the "White" state}}{\text{Luminance measured when LCD on the "Black" state}}$$

Note 5: Definition of Luminance Uniformity

Active area is divided into 9 measuring areas (reference the picture in below). Every measuring point is placed at the center of each measuring area.

$$\text{Luminance Uniformity (U)} = \text{Lmin/Lmax} \times 100\%$$

L = Active area length

W = Active area width

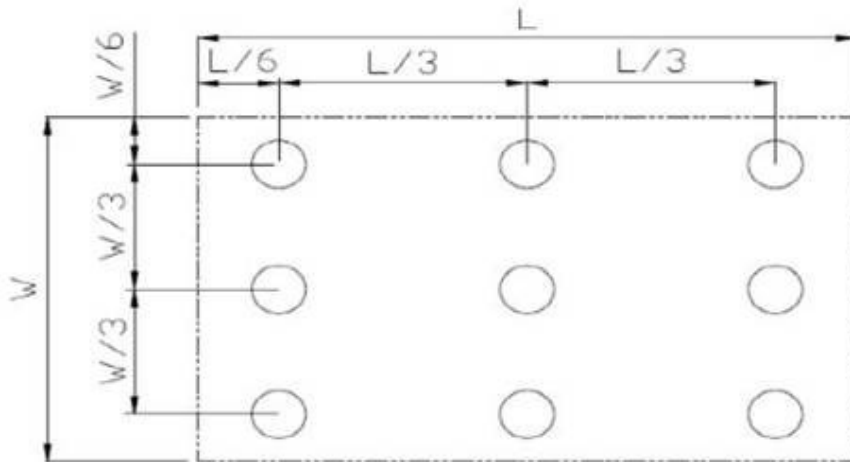

Fig 7.3. Definition of uniformity

Note 6: Definition of color chromaticity (CIE 1931)

Color coordinates measured at the center point of LCD

Note 7: Measured at the center area of the panel when all the input terminals of LCD panel are electrically opened.

8.Interface

8.1. LCM PIN Definition

Pin No.	Symbol	Function	Remark
1	DGND	Ground for digital circuit	
2	VCC	Power Supply : +3.3V	
3	VCC	Power Supply : +3.3V	
4	DGND	Ground for digital circuit	
5	VGL	Gate off power	
6	DGND	Ground for digital circuit	
7	VGH	Gate on power	
8	DGND	Ground for digital circuit	
9	UD	Up/down selection	
10	LR	Left /right selection	
11	SPENA	Chip select	
12	SPCK	Serial Clock	
13	SPDA	Serial Data	
14	NC	No connect	
15	DGND	Ground for digital circuit	
16	B5	Blue Data bus	
17	B4	Blue Data bus	
18	B3	Blue Data bus	
19	B2	Blue Data bus	
20	B1	Blue Data bus	
21	B0	Blue Data bus	
22	NC	No connection	
23	NC	No connection	
24	DGND	Ground for digital circuit	
25	G5	Green Data bit	
26	G4	Green Data bit	
27	G3	Green Data bit	
28	G2	Green Data bit	
29	G1	Green Data bit	
30	G0	Green Data bit	
31	NC	No connection	

32	NC	No connection	
33	AGND	Ground	
34	AVDD	Analog power: 10V	
35	AVDD	Analog power: 10V	
36	AGND	Ground	
37	R5	Red Data bit	
38	R4	Red Data bit	
39	R3	Red Data bit	
40	R2	Red Data bit	
41	R1	Red Data bit	
42	R0	Red Data bit	
43	DGND	Ground for digital circuit	
44	DGND	Ground for digital circuit	
45	DE	Data Enable input	
46	CLK	Data Clock	
47	HS	Horizontal sync input	
48	VS	Vertical sync input	
49	VCOM	VCOM driving input	
50	DGND	Ground for digital circuit	

8.2. Backlight PIN Definition

Pin No.	Symbol	Description
1	VLED+	Red, LED_ Anode
2	VLED-	Black, LED_ Cathode

9. Block Diagram

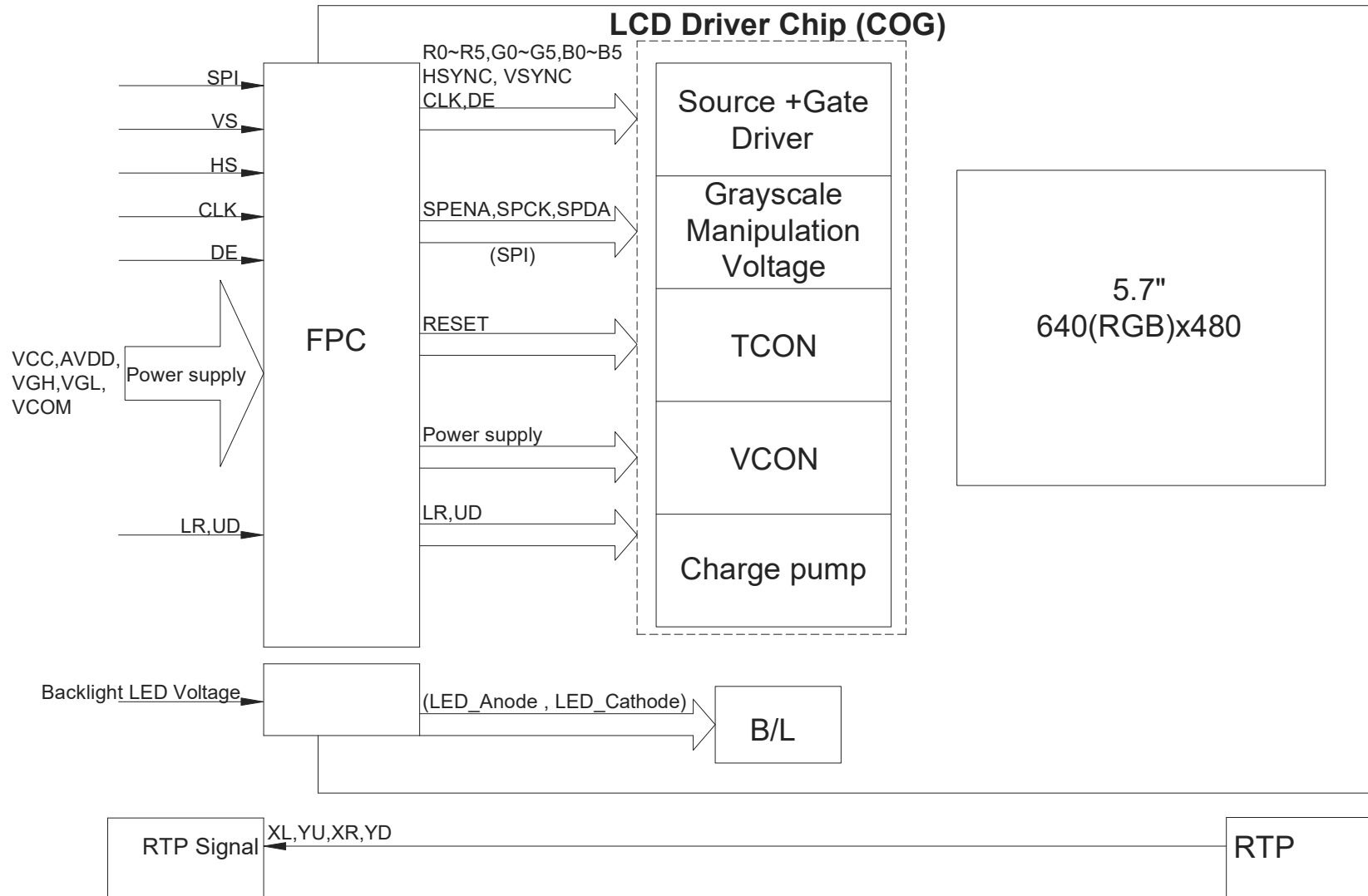

9.1.

10. Reliability

Content of Reliability Test (Wide temperature, -20°C~70°C)

Environmental Test			
Test Item	Content of Test	Test Condition	Note
High Temperature storage	Endurance test applying the high storage temperature for a long time.	80°C 200hrs	2
Low Temperature storage	Endurance test applying the low storage temperature for a long time.	-30°C 200hrs	1,2
High Temperature Operation	Endurance test applying the electric stress (Voltage & Current) and the thermal stress to the element for a long time.	70°C 200hrs	—
Low Temperature Operation	Endurance test applying the electric stress under low temperature for a long time.	-20°C 200hrs	1
High Temperature/ Humidity Operation	The module should be allowed to stand at 60°C,90%RH max	60°C,90%RH 96hrs	1,2
Thermal shock resistance	The sample should be allowed stand the following 10 cycles of operation <div style="text-align: center;"> <p style="margin: 0;">-20°C 25°C 70°C</p> <p style="margin: 0;">30min 5min 30min</p> <p style="margin: 0;">1 cycle</p> </div>	-20°C/70°C 10 cycles	—
Vibration test	Endurance test applying the vibration during transportation and using.	Total fixed amplitude : 1.5mm Vibration Frequency : 10~55Hz One cycle 60 seconds to 3 directions of X,Y,Z for Each 15 minutes	3
Static electricity test	Endurance test applying the electric stress to the terminal.	VS=±600V(contact), ±800v(air), RS=330Ω CS=150pF 10 times	—

Note1: No dew condensation to be observed.

Note2: The function test shall be conducted after 4 hours storage at the normal Temperature and humidity after remove from the test chamber.

Note3: The packing have to including into the vibration testing.

11.Touch Panel Information

NOTES: ALL MATERIALS AND COMPONENTS MUST BE RoHS COMPLIANT.

FRONT VIEW

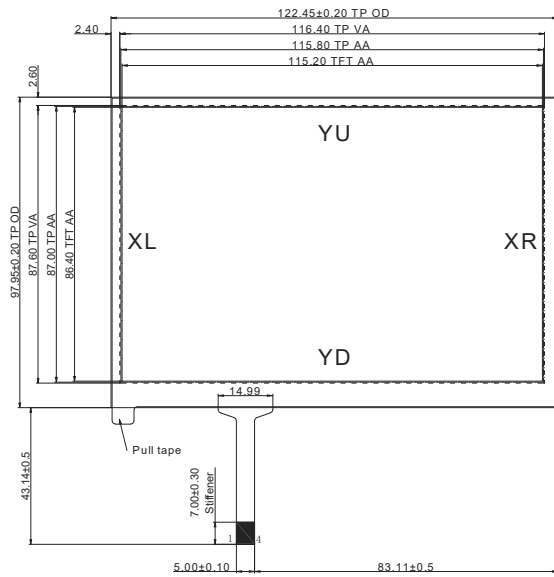

BACK VIEW

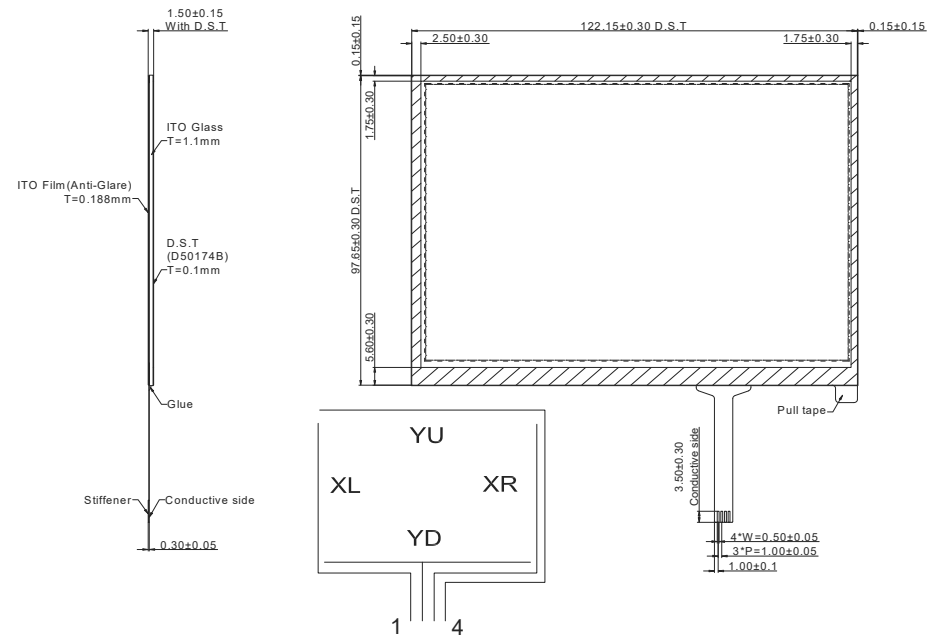

TOUCH PANEL PIN ASSIGNMENT

1	XL	Top Film Terminal
2	YD	Bottom Glass Terminal
3	XR	Top Film Terminal
4	YU	Bottom Glass Terminal

TOLERANCE NOT SPECIFIED: ±0.3mm

11.1. Resistance Touch Panel General Specifications

Item	Description
Supply voltage	DC 5V Max
Activation force	20~120g
Linearity	≤ 1.5%
(Insulation resistance	≥20MΩ (DC 25V)
Light transmission	70%
Structure type	ITO Film/ITO Glass(F/G)
Surface hardness	≥3H (Pencil)
Hitting life time	> 1000,000 times
Loop resistance	X: 200~900Ω
	Y: 200~900Ω

12. Contour Drawing

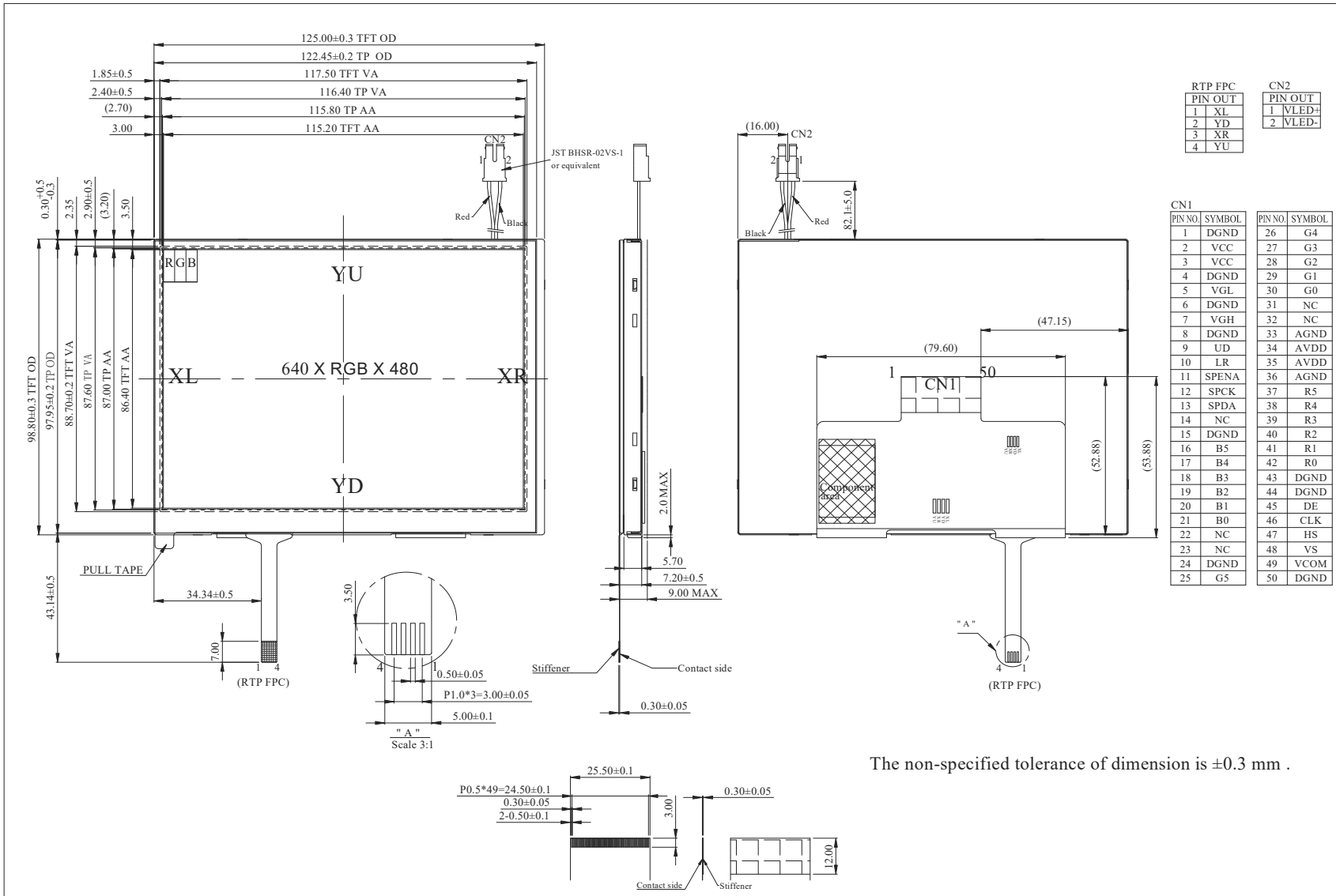

The non-specified tolerance of dimension is ±0.3 mm .



1、Panel Specification :

- 1. Panel Type : Pass NG , _____
- 2. View Direction : Pass NG , _____
- 3. Numbers of Dots : Pass NG , _____
- 4. View Area : Pass NG , _____
- 5. Active Area : Pass NG , _____
- 6. Operating Temperature : Pass NG , _____
- 7. Storage Temperature : Pass NG , _____
- 8. Others : _____

2、Mechanical

- 1. PCB Size : Pass NG , _____
- 2. Frame Size : Pass NG , _____
- 3. Material of Frame : Pass NG , _____
- 4. Connector Position : Pass NG , _____
- 5. Fix Hole Position : Pass NG , _____
- 6. Backlight Position : Pass NG , _____
- 7. Thickness of PCB : Pass NG , _____
- 8. Height of Frame to PCB : Pass NG , _____
- 9. Height of Module : Pass NG , _____
- 10. Others : Pass NG , _____

3、Relative Hole Size :

- 1. Pitch of Connector : Pass NG , _____
- 2. Hole size of Connector : Pass NG , _____
- 3. Mounting Hole size : Pass NG , _____
- 4. Mounting Hole Type : Pass NG , _____
- 5. Others : Pass NG , _____

4、Backlight Specification :

- 1. B/L Type : Pass NG , _____
- 2. B/L Color : Pass NG , _____
- 3. B/L Driving Voltage (Reference for LED Temperature) : Pass NG , _____
- 4. B/L Driving Current : Pass NG , _____
- 5. Brightness of B/L : Pass NG , _____
- 6. B/L Solder Method : Pass NG , _____
- 7. Others : Pass NG , _____

>> **Go to page 2** <<



Winstar Module Number : _____

Page: 2

5、Electronic Characteristics of Module :

- | | | | |
|------------------------------|-------------------------------|-------------------------------|-------|
| 1. Input Voltage : | <input type="checkbox"/> Pass | <input type="checkbox"/> NG , | _____ |
| 2. Supply Current : | <input type="checkbox"/> Pass | <input type="checkbox"/> NG , | _____ |
| 3. Driving Voltage for LCD : | <input type="checkbox"/> Pass | <input type="checkbox"/> NG , | _____ |
| 4. Contrast for LCD : | <input type="checkbox"/> Pass | <input type="checkbox"/> NG , | _____ |
| 5. B/L Driving Method : | <input type="checkbox"/> Pass | <input type="checkbox"/> NG , | _____ |
| 6. Negative Voltage Output : | <input type="checkbox"/> Pass | <input type="checkbox"/> NG , | _____ |
| 7. Interface Function : | <input type="checkbox"/> Pass | <input type="checkbox"/> NG , | _____ |
| 8. LCD Uniformity : | <input type="checkbox"/> Pass | <input type="checkbox"/> NG , | _____ |
| 9. ESD test : | <input type="checkbox"/> Pass | <input type="checkbox"/> NG , | _____ |
| 10. Others : | <input type="checkbox"/> Pass | <input type="checkbox"/> NG , | _____ |

6、Summary :

Sales signature : _____

Customer Signature : _____

Date : / / _____