

Data sheet

Commercial Art.No.: 25.155.2253.0

Printed circuit board terminal 8191 R / 2 Z

PCB terminal with screw connection with rising cage clamp system, 2 poles, printed version, with insulating plate, with solder pin (3.5mm), max. cross section: 2.5 mm², pitch: 5 mm, type of packing: carton, color: grey

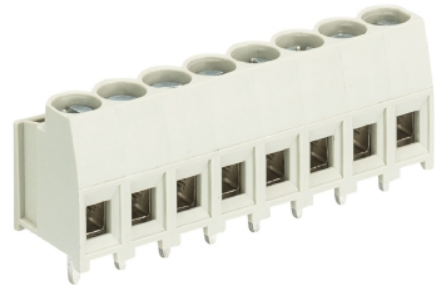

Commercial Art.No.	25.155.2253.0
EAN	4015573538085
Order Unit	500

Certificates / Approvals



Technical data

General

Modular spacing	5 mm
Connection type	screw connection
Soldering process	Wave soldering
Packaging	Carton
Number of poles	2
Conductor to circuit board	180°
Number of levels	1
Integrated test socket	No
Insulation plate	yes
Retaining pins	No
Marking	yes

Technical data

Nominal cross section	2.5 mm ²
Rated current	16 A
Overvoltage Category I	1000 V
Overvoltage Category II	690 V
Overvoltage Category III	250 V
Rated impulse voltage	4 kV
Wire strip length	6.5 mm

Connection Data

Minimum cross section solid	0.14 mm ²
Maximum cross section solid	4 mm ²
Minimum cross section fine stranded	0.14 mm ²
Maximum cross section fine stranded	2.5 mm ²

Wire strip length	6.5 mm
-------------------	--------

Technical Data UL/CSA

Cross section UL	22-12 AWG
Voltage UL	300 V
Current field wiring	20 A
Current factory wiring	30 A
Cross section CSA	22-12 AWG
Voltage CSA	300 V
Current CSA	25 A

Other

Type of insulation material	Thermoplastic
Color	Grey
Height	15 mm
Length	10.85 mm
Depth	11.5 mm
Material attachment screw	Steel
Material contact base	E-Cu
Material contact surface	Sn

Classification

ECLASS 11	
ECLASS 8.1	27440401
ETIM 7.0	EC002643
ETIM 6.0	EC002643
ETIM 5.0	EC002643
ETIM 4.0	EC002643

Product compliance

ROHS conformity status	Compliant/Exempted
ROHS exceptions	III-6(c)
REACH-SVHC conformity status	Duty-To-Declare
REACH-SVHC substances	Lead
REACH-SVHC CAS numbers	7439-92-1

Achtung/Attention!

Ausführungen mit oder ohne Beschriftung
Typ siehe Tabelle
version with or without marking
type see table

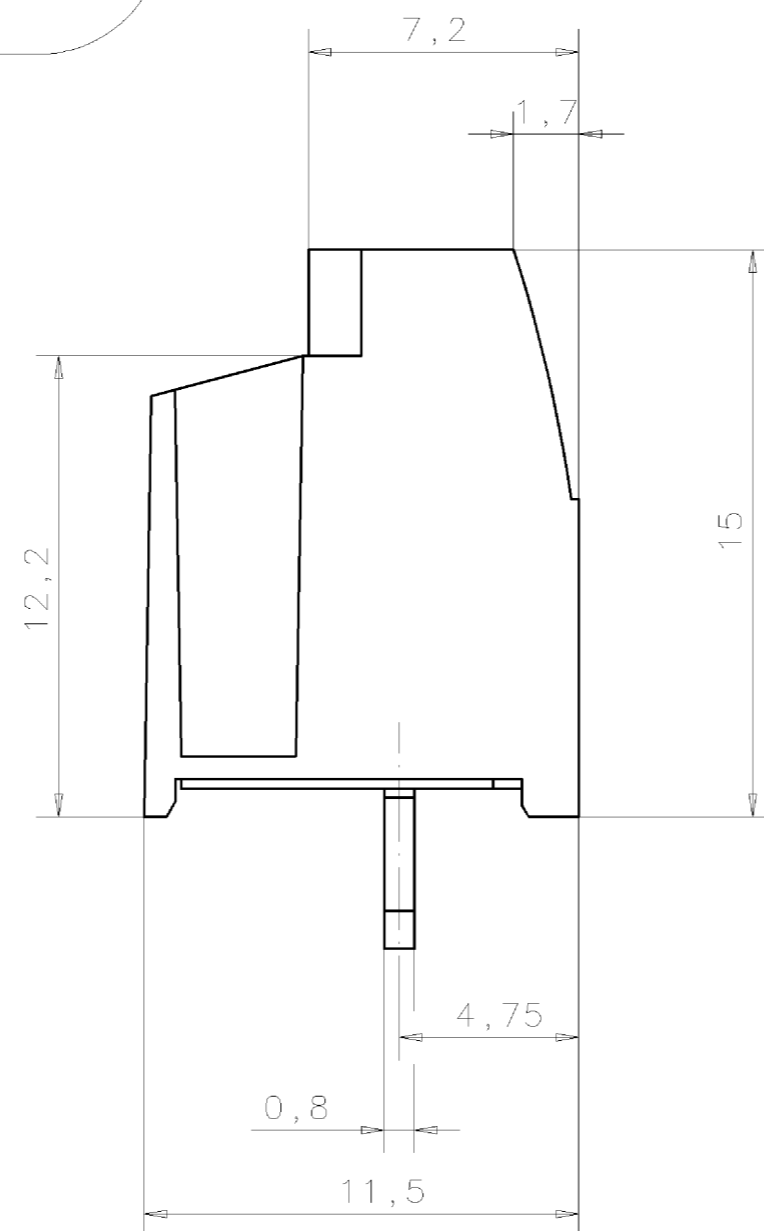
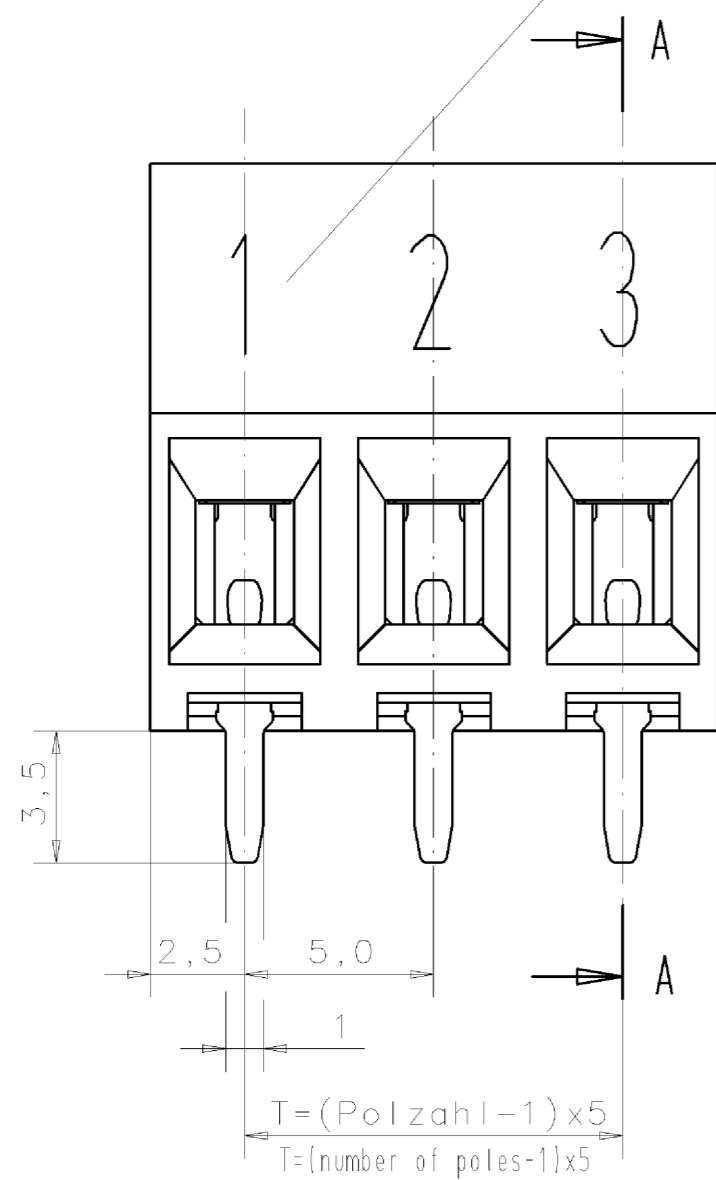

A-A

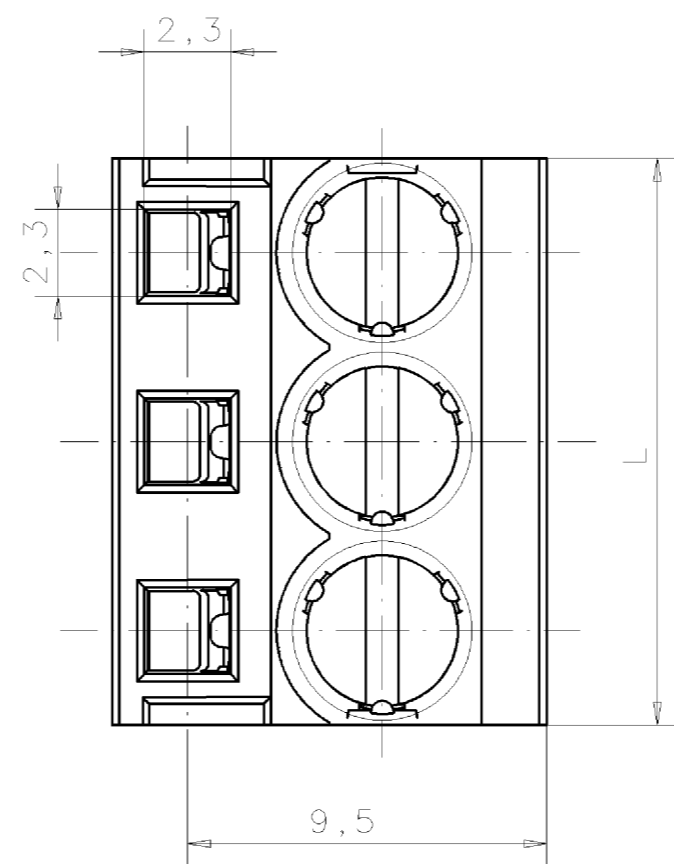
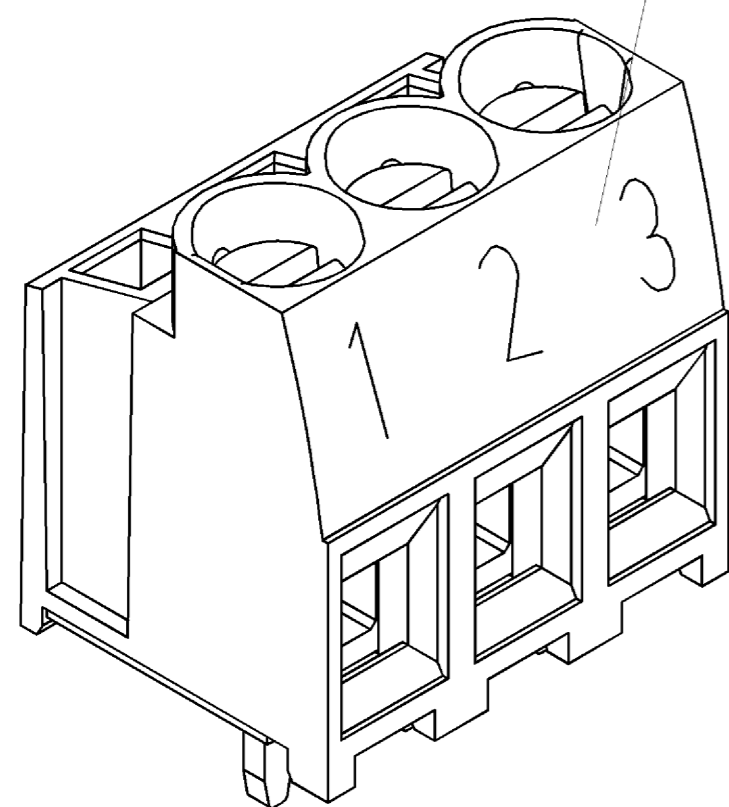
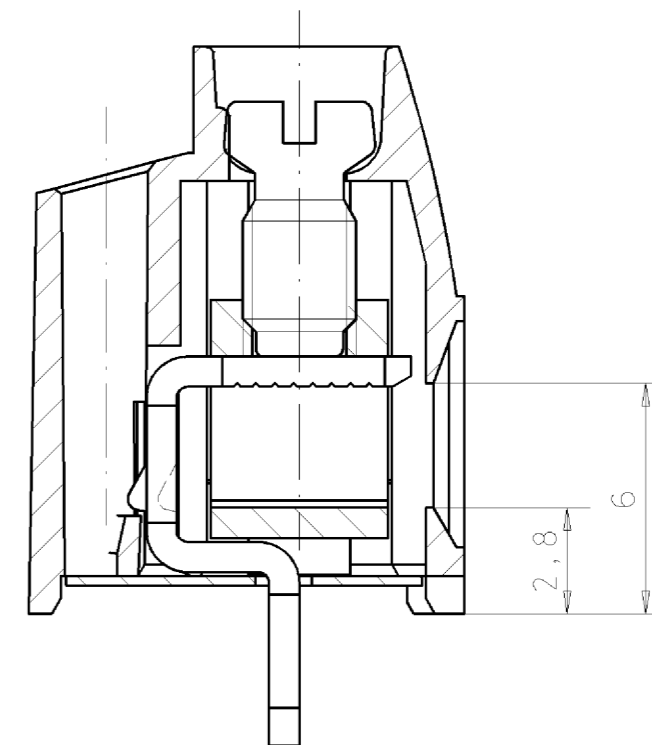

.F	Farbe/colour
.0	grau/grey
.1	schwarz/black

25.155.2253.F 25.155.3853.F	8191 R / 2 Z - 8191 R / 18 Z	2- 18	$T = (\text{Polzahl} - 1) \times 5$ (number of poles - 1) x 5	L=T+5	1-18
25.155.0253.F 25.155.1853.F	8191 R / 2 Z OB - 8191 R / 18 Z OB	2- 18	$T = (\text{Polzahl} - 1) \times 5$ (number of poles - 1) x 5	L=T+5	
Teile-Nr. part-no.	Typ type	Polzahl number of poles	T	L	Beschriftung marking

Tolerierung nach DIN 7167/Tolerance system acc. to DIN 7167. (This DIN-standard describes the envelope principle. According to the envelope principle the deviations of form and parallelism are limited by the size tolerances). ja/yes Stoffverhalts- und Deklarationsliste nach UU-TOM-05/03 ist einzuhalten. Conformity with Wieland document UU-TOM-05/03 (list of prohibited / declarable hazardous substances) to be declared!

Freitoleranz nach - CAD - Zeichnung, keine manuellen Änderungen EAD - drawing, no manual modifications allowed First Use: - Blatt: 1 von 1 Sheet: 1 of 1

Werkstoff/Material	2008	Tag/Date	Name	Zeichnung Nr./Drawing No.	Index
Maßstab/Scale	18.03.	Dutsch T.	T	25.155.0253.0 01K	
Vol.	mm	Offl./Surf.	mm	Maße in mm/Dimensions are in mm	
Ersatz für/Replacement for: -			Benennung/Title		
wieland			Type	PCB TERMINAL LP_KLEMME	
Elektrische Verbindungen			8191 R	250 V / 16 A / 2,5 mm ²	
Index	Datum / Blatt	Date / Sheet			
Änderung/Revision					

Weitere Daten siehe Katalog
further data see catalog

Weitergabe sowie Vervielfältigung dieses Dokuments, Verwertung und Mitteilung seines Inhalts sind verboten, soweit nicht ausdrücklich gestattet. Die Reproduktion und Verbreitung dieses Dokuments ist ohne schriftliche Genehmigung der Wieland-Werke AG.