

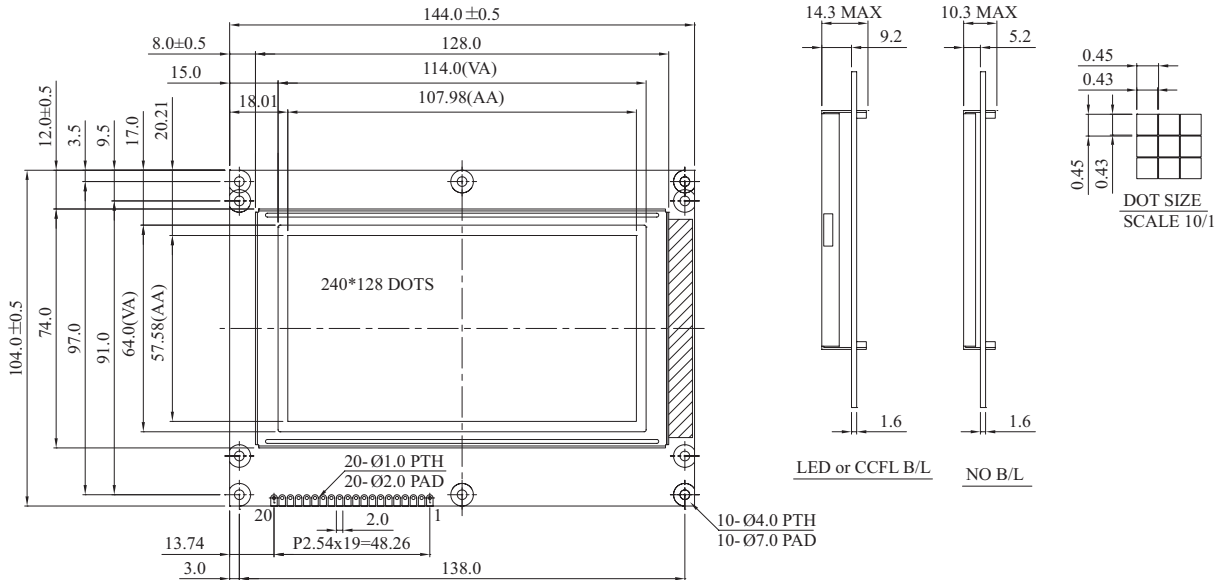

# WG240128D Graphic 240x128dots

## Dimension drawing



### Feature

1. Built-in controller SANYO- (LC7981 or equivalent)
2. +5V power supply
3. 1/128duty cycle
4. Built-in N.V

Pin NO	Symbol	Function
1	Vss	Power supply (GND)
2	Vdd	Power supply (+5V)
3	Vo	Contrast Adjustment
4	RS	Data /instruction select
5	RW	Data read write
6	E	Enable signal
7	DB0	Data bus line
8	DB1	Data bus line
9	DB2	Data bus line
10	DB3	Data bus line
11	DB4	Data bus line
12	DB5	Data bus line
13	DB6	Data bus line
14	DB7	Data bus line
15	CS	Chip select
16	RES	Reset signal
17	Vee	Negative Voltage output
18	NC	No connection
19	A	Power supply for B/L
20	K	Power supply for B/L

### Mechanical Data

Item	Standard Value	Unit
Module Dimension	144.0x104.0	mm
Viewing Area	114.0x64.0	mm
Dot Size	0.43x0.43	mm
Dot pitch	0.45x0.45	mm

### Absolute Maximum Rating

Item	Symbol	Standard Value			Unit
		min.	typ.	max.	
Power Supply	VDD-VSS	4.75	5.0	5.25	V
Input Voltage	VI	-0.3	---	VDD	V

Note : VSS=0 Volt, VDD=5.0 Volt.

### Electronical Characteristics

Item	Symbol	Condition	Standard Value			Unit
			min.	typ.	max.	
Input Voltage	VDD	L level	0.7V <sub>DD</sub>	---	V <sub>DD</sub>	V
	VIO	H level	---	---	0.3V <sub>DD</sub>	V
Supply Current	IDD	VDD=5V	0	55	60	mA
Recommended LC Driving Voltage for Normal Temp. Version module	VDD-V0	0°C	20.3	21.4	22.5	V
		25°C	18.0	19.1	20.2	
		50°C	17.8	18.9	20.0	
LED Forward Voltage	VF	25°C	---	4.2	---	V
LED Forward Current	IF	25°C	---	900	1800	mA
		25°C	---	---	5.5	
CCFL	VF	25°C	---	250	590	V <sub>rms</sub>
	IF	25°C	---	---	5.5	mA
EL	---	---	---	---	5.0	mA

Graphic type