

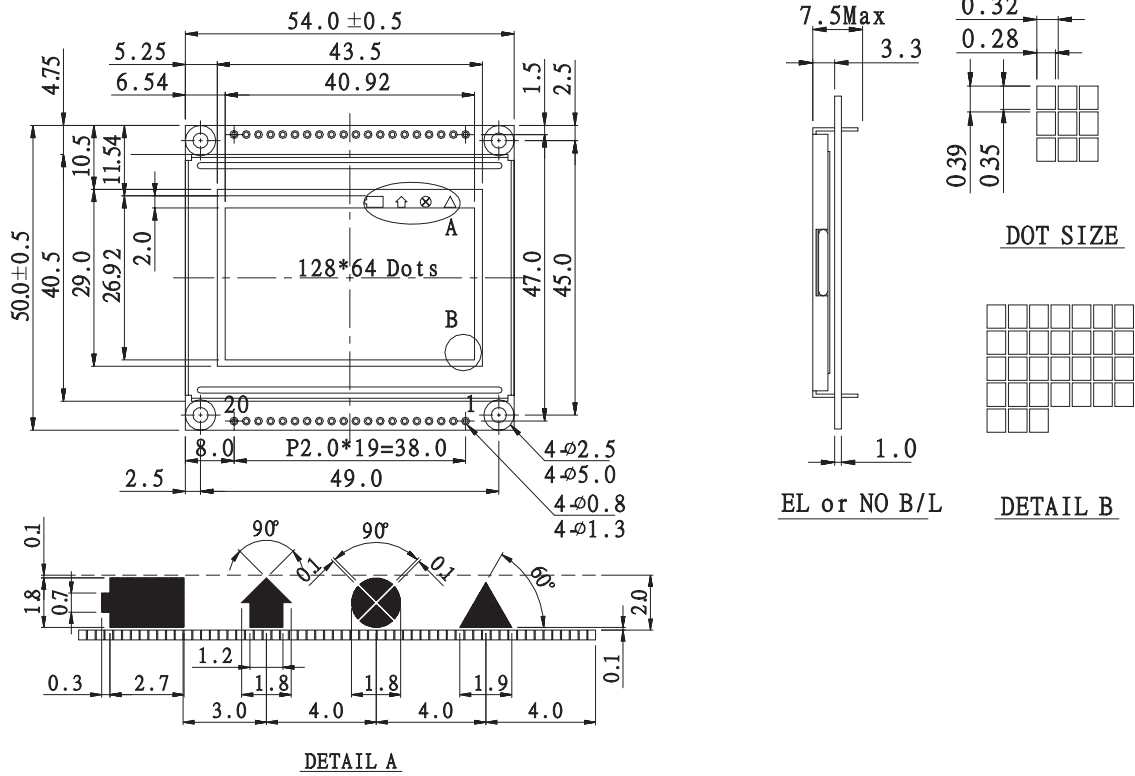

WG12864E/EP1 Graphic 128x64dots

Dimension drawing



Feature

1. 128x64 dots + 4 Icons
2. Built-in controller NT 7108
3. +5V power supply
4. 1/64 duty cycle
5. EL backlight (built-in EL inverter)
6. Built-in N.V
7. WG12864EP1: Array LED Y/G option, outline: 55.0x47.0mm
8. WG12864EP2: Outline same as WG12864EP1 W/O Icon

Mechanical Data

Item	Standard Value	Unit
Module Dimension	54.0x50.0x7.5	mm
Viewing Area	43.5x29.0	mm
Dot Size	0.28x0.35	mm
Dot Pitch	0.32x0.39	mm

Graphic type

Pin NO.	Symbol	Function
1	V _{SS}	Power supply(0V)
2	V _{DD}	Power supply
3	V _O	Operating voltage for LCD driving
4	D/I	Register selection input High=Data register Low=Instruction register(for write) Busy flag address counter(for read)
5	R/W	R/W signal input is used to select the read/write mode High=Read mode , Low=Write mode
6	E	Start enable signal to read or write the data
7	DB0	Data bus line
8	DB1	Data bus line
9	DB2	Data bus line
10	DB3	Data bus line
11	DB4	Data bus line
12	DB5	Data bus line
13	DB6	Data bus line
14	DB7	Data bus line
15	CS1	Chip enable for D2(segment 1 to segment 64)
16	CS2	Chip enable for D3(segment 65 to segment 128)
17	RST	Reset signal
18	V _{EE}	Power supply for LCD driving
19	BL+	Enable (on/off) for EL B/L
20	BL-	No connection

Absolute Maximum Rating

Item	Symbol	Standard Value			Unit
		min.	typ.	max.	
Power Supply	V _{DD} -V _{SS}	2.8	5	5.5	V
Input Voltage	V _I	-0.3	---	V _{DD}	V

Note : V_{SS}=0 Volt, V_{DD}=5.0 Volt.

Electronical Characteristics

Item	Symbol	Condition	Standard Value			Unit
			min.	typ.	max.	
Input Voltage	V _{DD}	L level	0.7V _{DD}	---	V _{DD}	V
	V _{IO}	H level	0	---	0.3V _{DD}	V
Supply Current	I _{DD}	V _{DD} =5V	---	10.0	---	mA
Recommended LC Driving Voltage for Normal Temp. Version module	V _{DD} -V _O	-20°C	9.3	9.5	9.8	V
		0°C	9.1	9.3	9.6	
		25°C	8.3	8.5	8.8	
		50°C	7.2	7.3	7.8	
EL Power Supply Current	I _{EL}	70°C	7.0	7.1	7.6	mA
		Vel=110VAC;400Hz	---	---	30.0	